

# Diphusair FLH

Electric Heater Steam Humidifiers



Manual



FLH.EN  
E-8881164

**▲ WARNING**

**Risk of electrical shock!**

Hazardous electrical high voltage!

All electrical work to be performed by certified expert staff (electricians or expert personnel with equivalent training) only.

---

<b>1. Introduction .....</b>	<b>5</b>
1.1 Typographic Distinctions .....	5
1.2 Documentation .....	5
1.3 Symbols in Use .....	5
1.3.1 Specific Symbols related to Safety Instructions .....	5
1.3.2 General Symbols .....	5
1.4 Intended Use .....	6
<b>2. Safety Instructions .....</b>	<b>7</b>
2.1 Guidelines for Safe Operation .....	7
2.1.1 Scope .....	7
2.1.2 Unit control .....	7
2.1.3 Unit Operation .....	7
2.1.4 Mounting, dismantling, maintenance and repair of the unit .....	8
2.1.5 Electrical .....	8
2.2 Disposal after dismantling .....	8
<b>3. Transport .....</b>	<b>9</b>
3.1 Overview .....	9
3.2 Packing .....	9
3.3 Interim Storage .....	9
3.4 Check for Complete and Correct Delivery of Goods .....	9
<b>4. Functional Description and Device Composition .....</b>	<b>10</b>
4.1 Mode of Action .....	10
4.2 Operational sequence .....	11
4.3 Internal Output Setting .....	11
4.4 Mechanical Construction .....	11
<b>5. Mechanical installation .....</b>	<b>12</b>
5.1 Environment Parameters to be met and Mounting Recommendations .....	12
5.1.1 Dimensions and Mounting Directions .....	13
5.2 Unit Installation Check .....	16
5.3 Absorption Distance BN .....	17
5.3.1 Determining the Absorption Distance .....	17
5.3.2 Absorption Distance Nomogram .....	18
5.4 Steam Manifold .....	19
5.4.1 General installation guidelines .....	19
5.4.2 Recommendations for dimensioning .....	19
5.5 Steam line and condensate hose layout .....	22
5.5.1 Guide lines for steam line design .....	22
5.5.2 Condensate hose layout .....	22
5.5.3 Steam line and condensate hose installation types .....	23
<b>6. Water connection .....</b>	<b>24</b>
6.1 Water supply .....	24
6.2 Water discharge .....	26
6.3 Water connections final check .....	27

---

<b>7. Electrical connection .....</b>	<b>28</b>
7.1 Electrical installation approach .....	28
7.2 Cable connections .....	29
7.3 Safety interlock .....	30
7.4 Connection diagram .....	30
7.5 Electrical installation check list .....	30
<b>8. Commissioning .....</b>	<b>31</b>
<b>9. Maintenance .....</b>	<b>32</b>
9.1 General .....	32
9.1.1 Service messages .....	32
9.1.2 Service messages for preventive maintenance .....	32
9.1.3 Safety instructions for maintenance .....	33
9.2 Maintenance frame work when unit is operated with fully demineralised water and condensate 34	
9.3 Maintenance when unit is operated with tap water or partially softened water .....	34
9.4 Removing and cleaning the steam cylinder .....	35
9.5 Steam cylinder and cylinder base cleaning .....	39
9.6 Level control device cleaning .....	40
9.7 Heater element replacement .....	41
9.8 Thermo switch replacement (for heater elements) .....	41
9.9 Releasing a thermo switch that has triggered .....	42
9.10 Inspection of wiring connections and heater element wiring .....	42
9.11 Removal and reinstallation of the solenoid valve including fine filter cleaning .....	43
9.12 Cleaning of blow-down pump .....	44
9.13 Inspection of hoses .....	44
9.14 Functional check .....	44
9.15 Completion of maintenance .....	45
<b>10. Dismantling .....</b>	<b>46</b>
<b>11. Declaration of Conformity .....</b>	<b>47</b>
<b>12. Spare Parts .....</b>	<b>48</b>
<b>13. Technical specifications .....</b>	<b>50</b>
<b>14. Exploded view .....</b>	<b>52</b>
<b>15. View of housing .....</b>	<b>53</b>

## 1. Introduction

### Dear Customer,

Thank you for choosing a Fisair steam humidifier.

Fisair steam humidifiers represent the latest in humidification technology.

In order to operate your Fisair steam humidifier safely, properly and efficiently, please read these operating instructions.

Employ your steam humidifier only in sound condition and as directed. Consider potential hazards and safety issues and follow all the recommendations in these instructions.

If you have additional questions, please contact your expert dealer.

For all technical questions or spare parts orders, please be prepared to provide unit type and serial number (see name plate on the unit).

### 1.1 Typographic Distinctions

- preceded by a bullet: general specifications
- » preceded by an arrow: Procedures for servicing or maintenance which should or must be performed in the indicated order
- ☑ Installation step which must be checked off.

*italics* Terms used with graphics or drawings

### 1.2 Documentation

#### Retention

Please retain these operating instructions in a secure, always accessible location. If the product is resold, turn the documentation over to the new operator. If the documentation is lost, please contact Fisair.

### Versions in Other Languages

These operating instructions are available in several languages. If interested, please contact Fisair or your Fisair dealer.

### 1.3 Symbols in Use

#### 1.3.1 Specific Symbols related to Safety Instructions

According to EN 82079-1 (and ANSI Z535.6), the following signal words are used within this document:

#### **▲ DANGER**

DANGER indicates a hazardous situation which, if not avoided, will result in death or serious injury.

#### **▲ WARNING**

WARNING indicates a hazardous situation which, if not avoided, could result in death or serious injury.

#### **▲ CAUTION**

CAUTION indicates a hazardous situation which, if not avoided, could result in minor or moderate injury.

#### **NOTICE**

NOTICE is used to address practices not related to physical injury.

#### 1.3.2 General Symbols

#### **Please note**

This symbol is used whenever a situation requires special attention beyond the scope of safety instructions.

## 1.4 Intended Use

Fisair electric heater steam humidifiers serve for steam production based on tap water, partially softened water or fully desalinated water/cleaned condensate.

Proper usage also comprises the adherence to the conditions specified by Fisair for:

- installation
- dismantling
- reassembly
- commissioning
- operation
- maintenance
- disposal.

Only qualified personnel may operate the unit. Persons transporting or working on the unit must have read and understood the corresponding parts of the Operation and Maintenance Instructions and especially the chapter 2. „Safety Notes“.

Additionally, operating personnel must be informed of any possible dangers by the provider. A copy of this manual is to be placed at the unit's operational location.

**By construction, Fisair steam humidifiers are not qualified for exterior application.**

### **⚠ WARNING**

#### **Risk of scalding!**

Steam with a temperature of up to 100 °C (212 °F) is produced.

Do not inhale steam directly!

---

## 2. Safety Instructions

These safety instructions are required by law. They promote workplace safety and accident prevention.

### 2.1 Guidelines for Safe Operation

#### 2.1.1 Scope

Comply with the accident prevention regulation „DGUV Regulation 3“ to prevent injury to yourself and others. Beyond that, national regulations apply without restrictions.

#### 2.1.2 Unit control

Do not perform any work which compromises the safety of the unit. Obey all safety instructions and warnings present on the unit.

In case of a malfunction or electrical power disruption, switch off the unit immediately and prevent a restart. Repair malfunctions promptly.

#### **⚠ WARNING**

##### **Restricted use.**

IEC 60335-1 stipulates as follows:

This device may be used by children of eight years of age and above as well as by persons with reduced physical, sensory or mental capabilities or lack of experience and knowledge so long as they are supervised or have been instructed regarding the safe use of the device and understand the hazards that may result from it. Cleaning and user maintenance of the unit must not be undertaken by children without supervision.

#### 2.1.3 Unit Operation

#### **⚠ WARNING**

##### **Risk of scalding!**

Uncontrolled hot steam escape in case of leaking or defective components possible. Switch off unit immediately.

#### **NOTICE**

##### **Risk of material damage!**

The unit may be damaged if switched on repeatedly following a malfunction without prior repair.

Rectify defects immediately!

The unit must not be operated on a DC power supply.

The unit may only be used connected to a steam pipe that safely transports the steam.

Regularly check that all safety and monitoring devices are functioning normally. Do not remove or disable safety devices.

## 2.1.4 Mounting, dismantling, maintenance and repair of the unit

### **NOTICE**

The Fisair steam humidifier is IP20 protected. Make sure that the unit is not object to dripping water in the mounting location.

Installing a humidifier in a room without water discharge requires safety devices to protect against water leakages.

---

- Use genuine spare parts only
- After any repair work, have qualified personnel check the safe operation of the unit
- Attaching or installing of **additional components** is permitted only with the **written consent** of the manufacturer

## 2.1.5 Electrical

### **⚠ WARNING**

#### **Risk of electrical shock!**

Hazardous electrical voltage!

Any work on the electrical system to be performed by certified expert staff (electricians or expert personnel with comparable training) only.

Disconnect unit components from electrical power supply prior to work.

After electrical installation or repair work, test all safety mechanisms (such as grounding resistance).

---

### **NOTICE**

Use only original fuses with the appropriate amperage rating.

Regularly check the unit's electrical equipment. Promptly repair any damage such as loose connections or burned wiring.

Responsibility for intrinsically safe installation of the Fisair steam humidifiers is incumbent on the installing specialist company.

---

## 2.2 Disposal after dismantling

### **NOTICE**

The operator is responsible for the disposal of unit components as required by law.

---

### 3. Transport

#### 3.1 Overview

**Please note**

Proceed carefully when transporting the steam humidifier in order to prevent damage due to stress or careless loading and unloading.

#### 3.2 Packing

**Please note**

Pay attention to the icons affixed to the packing box.

#### 3.3 Interim Storage

Store the unit in a dry place and protect from frost and strong sunlight.

#### 3.4 Check for Complete and Correct Delivery of Goods

Upon receipt of the unit, confirm that:

- model and serial number on the name plate match those specified in the order and delivery documents
- the equipment is complete and all parts are in perfect condition

**Please note**

In case of damage from shipment and/or missing parts, immediately notify the carrier or supplier in writing.

Time limits for filing freight claims with shipping companies are\*:

Shipping company	After receipt of goods
Carriers	no later than 4 days
Parcel service	immediately

\* Time limits for some services subject to change.

## 4. Functional Description and Device Composition

### 4.1 Mode of Action

#### The immersion heater principle

Depending on the output rating, one, three or six heater elements are arranged within a closed cylinder. The FlexLine humidifiers FLH80 and FLH100 combine two steam cylinders in one housing.

Exemplary given, the figure below shows the heater element and other main components of a FlexLine steam generator model with one steam cylinder.

The cylinder(s) are filled with either tap water of varying quality, fully desalinated water or partially softened water.

The heat introduced by the heater elements heats up the cylinderwater to approx. 100 °C (212 °F), transforming the water into steam

with a temperature of approx. 100 °C (212 °F) This steam is virtually mineral-free and germ-free.

When fully desalinated water is used, the cylinder water is almost totally clear of minerals. This situation guarantees a long lifetime of the cylinder(s) and the heater element(s), since virtually no hardeners will fall-out and no mineral deposits will occur. Such, the number of inspections and/or maintenance operations required will be reduced to a minimum.

When tap water is used for operation, some of the minerals dissolved in the water are likely to settle in the cylinder in form of solids of various compositions. However, most of the solids are flushed out by cyclic blow-down with the help of a heavy-duty blow-down pump.

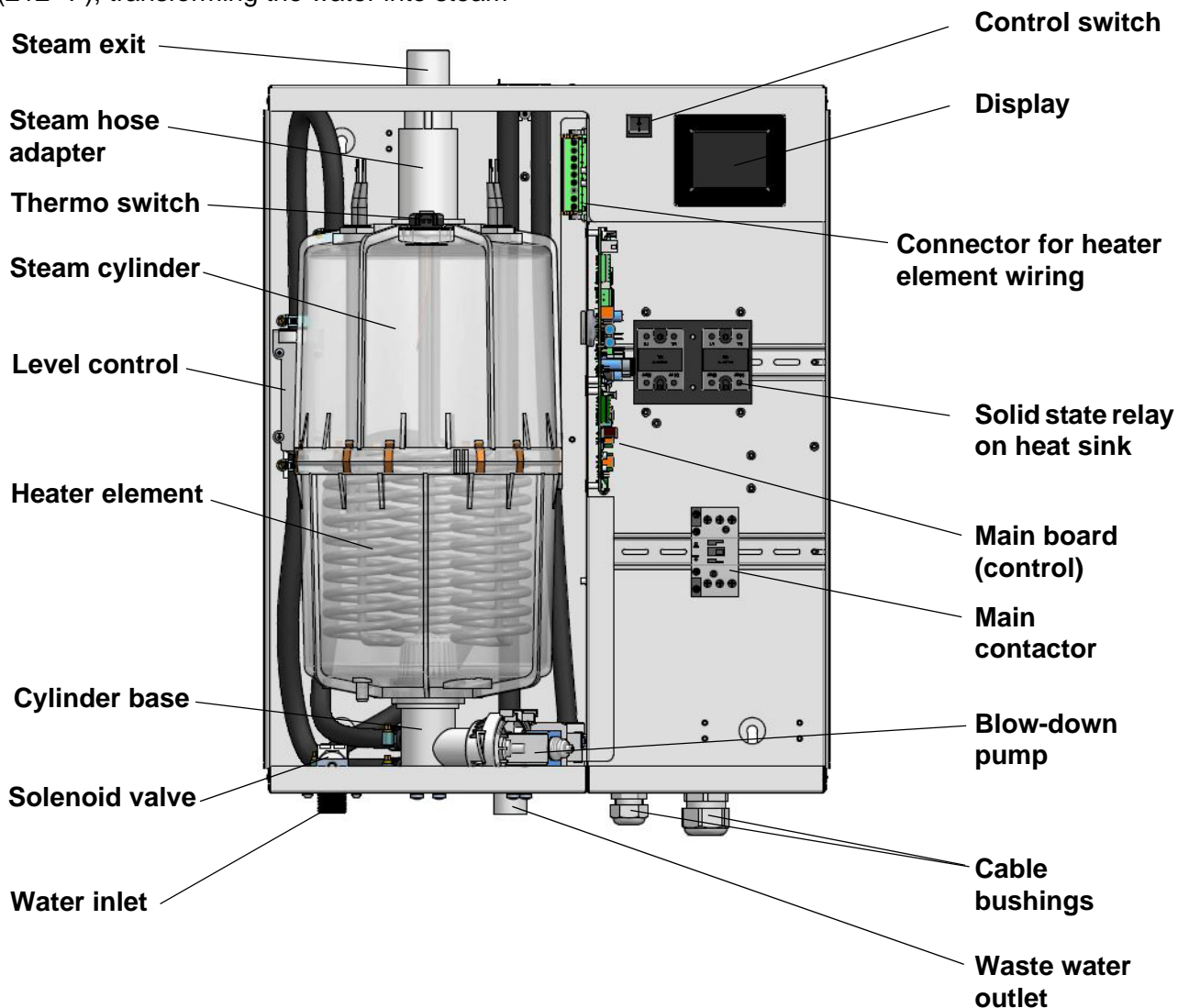

## 4.2 Operational sequence

The steam humidifier is switched on by pressing the control switch on the front panel to the „I“ position. If the safety chain is closed, the inlet solenoid valve (25)<sup>\*</sup> opens and water is fed into the steam cylinder.

Filling level in the cylinder is controlled by a level control device (27)<sup>\*</sup>). In a plastic cylinder, connected to the steam cylinder via hoses in the way communicating tubes are connected, a sensor for continuous proportional water level survey is located.

The cylinder water is periodically blown down. For usage of the unit with fully desalinated water, the blow-down function may be blocked.

Water blow-down is achieved by means of the blow-down pump (32)<sup>\*</sup>) that is continuously monitored during unit operation. In case of pump disruption, the Fisair steam humidifier is shut off.

With normal water quality, blow-down loss is in the range of 7 to 15% of the steam amount produced. Depending on water quality, a full steam cylinder blow-down is run every 3 to 8 days.

Mineral deposits settle in the open area below the heater element(s) and are removed through periodic maintenance. The blow-down pump itself has wide openings and can flush out smaller pieces of mineral deposit. This extends the service life of the unit and reduces the required maintenance interval.

On blow-down, water flows from the pump into the drain hose system.

For maintenance purposes, the cylinder water may be pumped out by pressing and holding the control switch in the „II“ position.

<sup>\*</sup>) numbers indicated correspond with those in the exploded view in the „Exploded view“ chapter.

## 4.3 Internal Output Setting

Continuous control is achieved by proportional driving (pulse width modulation) of one of the heater elements and phased addition of further elements. In this way the humidifier can be proportionally operated across the entire output range of 5% - 100% of the nominal capacity.

A power setting of 0% to 5% of the nominal output is possible, but not technically feasible due to condensate losses in the steam line.

## 4.4 Mechanical Construction

The Fisair FLP series units feature a stainless steel steam cylinder and - as an ordering option - a fourfold solenoid valve for the exceedingly precise steam control.

The type of housing is designed for wall mounting.

## 5. Mechanical installation

### **▲ WARNING**

#### **Risk of foot injuries!**

Prevent unit from dropping during installation!  
Helping hand of a second person is advisable.

### **▲ WARNING**

#### **Risk of electrical shock!**

Hazardous electrical voltage.  
During installation, the unit must be disconnected from power supply.

### 5.1 Environment Parameters to be met and Mounting Recommendations

When selecting the installation site for the steam humidifier, take the following into account:

- The minimum clearances indicated in the fitting measures section must be observed in order to ensure adequate unit ventilation and allow for unobstructed access in case of maintenance
- Protection class IP20
- By design, Fisair steam humidifiers are not qualified for outdoor installation (electronical components and water-bearing parts may be damaged)
- Ambient temperature must lie between +5 and +40 °C (+41 and +104 °F) in order to protect the unit electronics against damage; frost may damage the steam cylinder, the solenoid valve and pump, as well as make hoses burst
- Relative humidity must not exceed 80 % r.h., since values beyond may lead to electronic malfunction or damage

- Installation in a closed room requires aeration and, eventually, temperature conditioning in order to meet the a.m. environmental conditions
- The steam humidifier should be installed as close as possible to the steam manifold. Optimum performance is only guaranteed when steam and condensate hoses are kept short
- Make use of existing water connections for supply and draining
- Hoses must be laid at a consistent 5 to 10 % incline/decline; sagging and kinking prevention is a must
- Mount the unit on a stable, preferably solid wall offering the bearing capacity required (s. unit technical specifications). If such a wall is not at hand, the unit may be attached to a stand bracket firmly bolted to the floor
- For proper functioning of the level control, plumb and level installation of the unit is required
- The steam humidifier rear panel heats up during operation to a maximum of 70 °C (158 °F). Take care that the construction on which the unit is to be mounted is not made of temperature-sensitive material

### 5.1.1 Dimensions and Mounting Directions

Table of dimensions

Model	X [mm/inch]	Y [mm/inch]	Z [mm/inch]	A [mm/inch]	B[mm/inch]
FLH03-FLH09	540/~21.3	535/~21	320/~12.6	390/~15.4	400/~15.7
FLH15-FLH25	540/~21.3	695/~27.4	320/~12.6	390/~15.4	560/~22
FLH40-FLH50	640/~25	785/~30.9	420/~16.5	490/~19.3	650/~25.6
FLH80-FLH100	1170/~46	785/~30.9	420/~16.5	1000/~39.4	660/~25.6

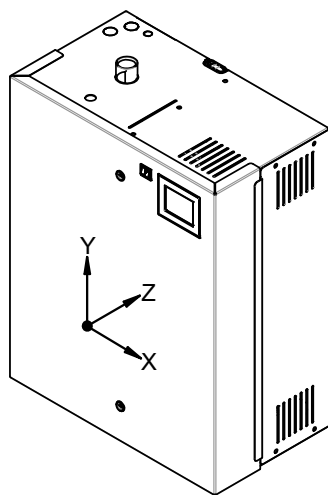
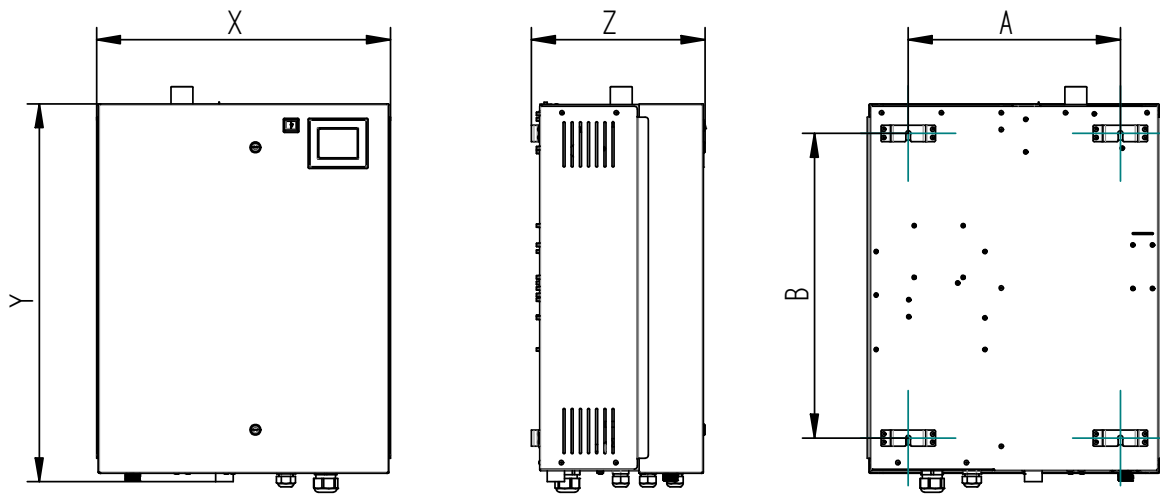

### Wall clearances

When mounting the steam humidifier, the wall clearances shown in the fig. below must be obeyed:

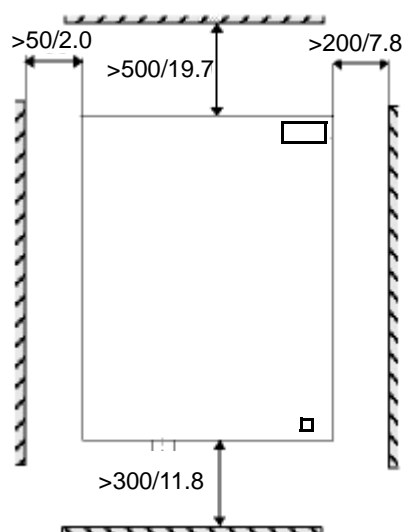

all measures in mm/inch

For wall mounting drill measures, please consult the table above (measure A and B). In case of no suitable wall available for mounting the unit, it is recommended that installation is made on brackets firmly anchored in the floor.

- » mark the holes for the upper suspension brackets screws
- » drill holes and dowel
- » screw in the supplied mounting screws; let the screws protrude approx. 12 mm/.5 inch from wall
- » ensure firm fixation and load-carrying capacity of the mounted screws!
- » hook in the unit and ensure safe suspension
- » mark the holes for the lower suspension brackets screws
- » remove the unit
- » drill holes and dowel
- » hook in the unit and mount the lower screws firmly

To function properly, the steam humidifier must hang level and plumb.

### Mounting principle

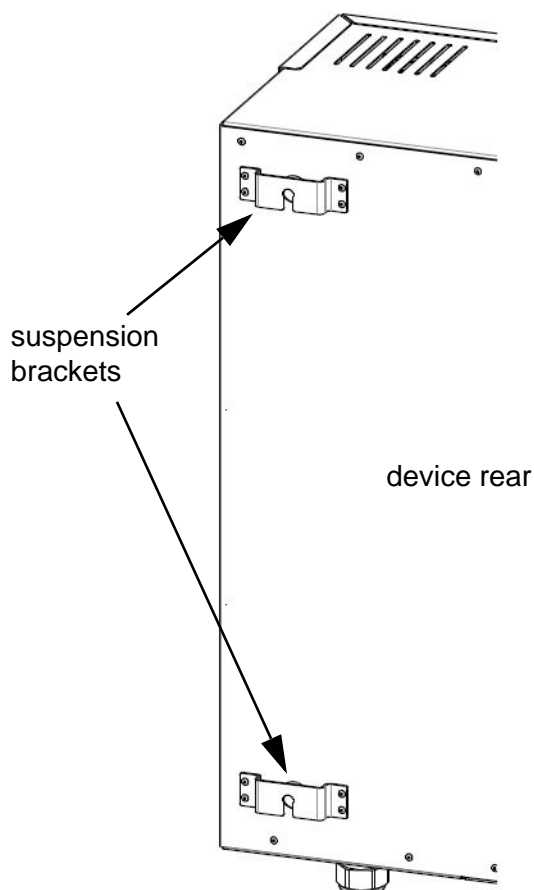

**Device connections:**

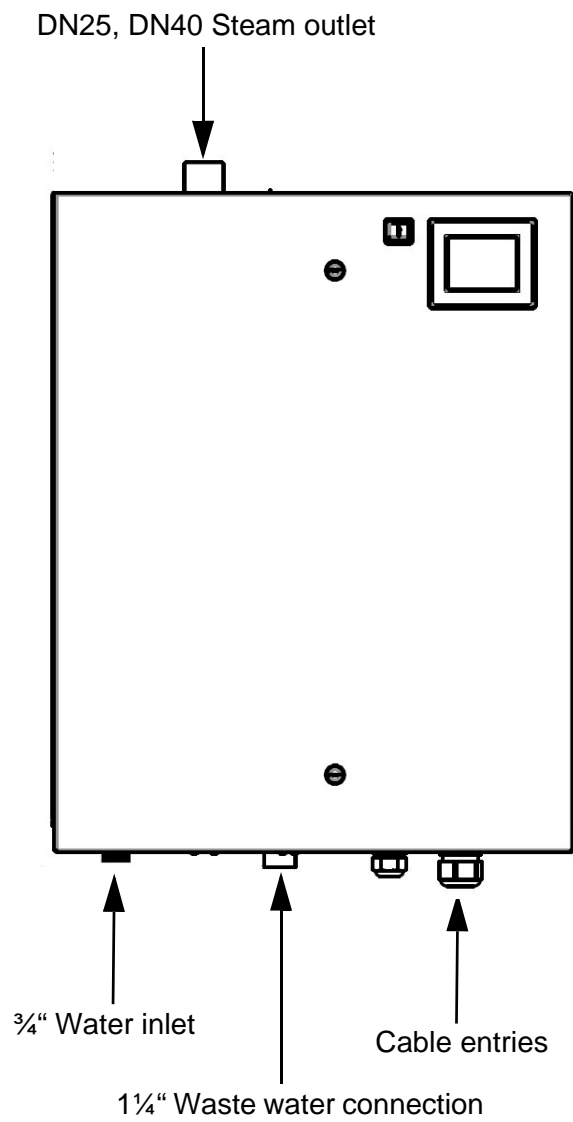

---

## 5.2 Unit Installation Check

Before start-up, pls. check proper unit installation following the list below:

- Unit perpendicularly aligned in both the vertical and horizontal axis ?
- All clearances obeyed?
- Steam hose installed with a 5 - 10 % minimum incline/decline (see chapter "Steam line") ?
- Condensate hose features a loop functioning as a steam barrier (see chapter „Condensate hose“) ?
- Steam manifold(s) properly positioned?
- All bolts and clamps properly tightened?
- Steam manifold(s) horizontally mounted and suspended on the free end, if required ?
- All seals (o-rings) in place?
- All ventilation slots on housing top unobscured?

### 5.3 Absorption Distance $B_N$

The "absorption distance" ( $B_N$ ) is defined as the distance from the steam feed to where the steam is completely absorbed in the treated air. Within the absorption distance, steam is visible as mist in the air stream.

Condensation may occur on anything installed within the absorption distance.

Although steam outside the absorption distance ( $B_N$ ) is completely absorbed, it is not yet evenly diffused in the duct. If you plan to install any parts or devices inside the absorption distance, such as sensors or elbows, we recommend increasing the absorption distance using the formulae below. The absorption distances required for certain installed fittings are distinguished by separate symbols and calculated as a multiplier of the absorption distance  $B_N$ .

Absorption Distance	
$B_N$	for normal obstructions such as sensors, ventilators, outlets
$B_C = (1.5...2) \times B_N$	for fine filters, heat registers
$B_S = (2.5...3) \times B_N$	for particle filters
$B_d = (3...5) \times B_N$	for humidity sensors, duct humidistats

The absorption distance has no fixed value, but depends on many factors. These are depicted in the absorption distance nomogram below.

#### 5.3.1 Determining the Absorption Distance

To determine the absorption distance, the following parameters are required:

- Air humidity before humidification  $x_1$  in g/kg
- Air temperature after humidification  $t_2$  in °C (with steam humidifiers the change in air temperature due to humidification may be disregarded  $t_1$  or  $t_2$ )
- Specific increase in humidity  $\Delta x$  in g/kg (can be determined in the h,x diagram)

- quantity of steam introduced  $m_D^o$  in kg/h.
- air speed  $w_L$  in m/s in air duct
- Total length  $l_D$  of the steam manifold installed in the air duct

Length  $l_D$  of the usable steam manifold depends on the dimensions of the air duct. The length of the absorption distance can be reduced by using multiple steam manifolds (also see section on the steam manifold).

#### Method:

Graphically determine absorption distance  $B_N$  using the absorption distance nomogram (also see Section „Absorption Distance Nomogramm“). Enter the value of the parameters enumerated above into the respective quadrants. The resulting point of intersection indicates the value of the desired absorption distance  $B_N$ .

#### Notes:

Air humidity before humidification  $x_1$ :.....[g/kg]

Air temperature after humidification  $t_2$ :.....[°C]

Specific increase in humidity  $\Delta x$ :.....[g/kg]

Quantity of steam introduced  $m_D^o$  :.....[kg/h]

Air speed  $w_L$ :.....[m/s]

Total length of steam manifold  $l_D$ :.....[mm]

### 5.3.2 Absorption Distance Nomogram

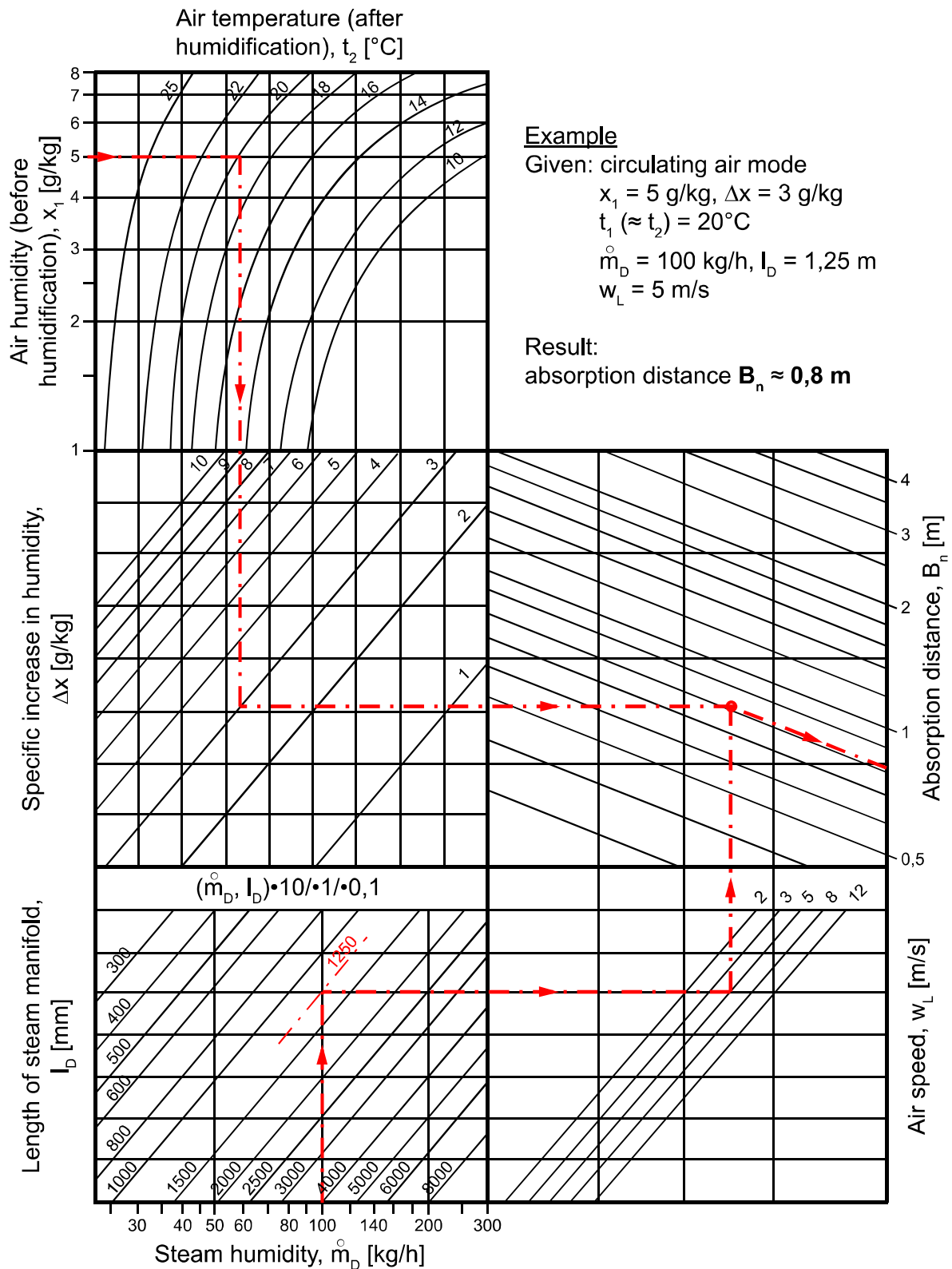

Source: Henne, Erich: Luftbefeuchtung (Air Humidification), 3<sup>rd</sup> Edition 1984 (Page 101), Oldenbourg Industrieverlag, Munich

## 5.4 Steam Manifold

### 5.4.1 General installation guidelines

When installing steam manifolds, pls. follow these guidelines:

#### Positioning within duct

- Install the steam manifold as close as possible to the steam humidifier in order to minimize steam loss through condensation
- Steam manifold placement on the supply side of the air duct is preferable
- Install steam manifold strictly horizontal in order to ensure proper condensate drain
- Shown installation and positioning dimensions are based on empiric values. Special environmental conditions may require adjustments. Pay special attention to avoid condensate generation in air duct

#### Allowable pressures

- Max. allowable pressure in air duct is 1200 Pa (.174 PSI)
- On suction side, max. -500 Pa (.07 PSI) is tolerable
- With high-pressure air conditioning systems, modifications of the unit's drain hose system may possibly be required depending on the overall pressure situation. These modifications must be **coordinated with your expert dealer.**

#### Water drain

- We point out that according to the German Association of engineers (VDI) guideline VDI 6022, a water drain must be provided within the absorption distance inside the air duct

#### When increased airflow speed is encountered

- Air flow rates beyond 3m/s (9.84 ft/s) may lead to condensate drainage problems at the steam manifolds due to vacuum built-up. A possible remedy is twisting the steam manifold in its horizontal axis by few angular degrees. In case of problems, pls. consult your expert dealer.

### 5.4.2 Recommendations for dimensioning

The recommendations given below are based on homogenous air flow in the duct.

#### Horizontal installation of steam manifold

##### Standard steam manifold arrangement:

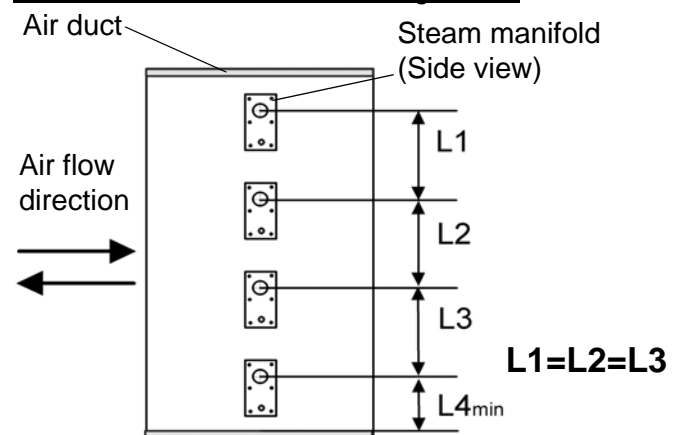

An even distribution of steam manifolds ensures a uniform steam distribution.

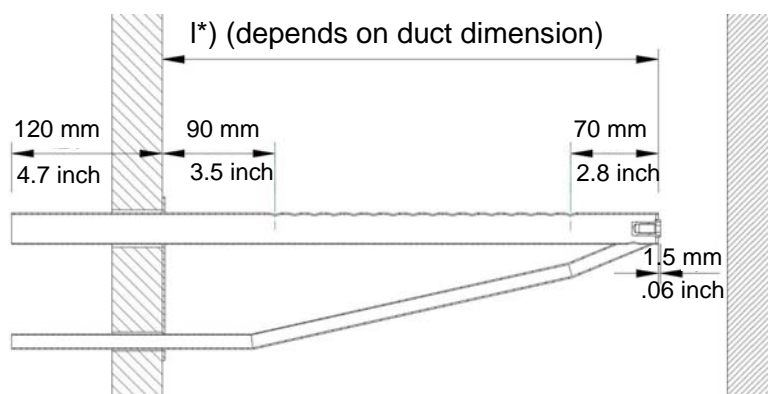

Please use the total height of the duct!

\*) s. table of manifold lengths **Horizontal assembly position in duct**

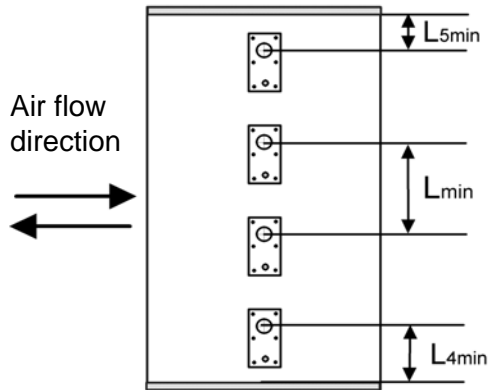

Minimum distance for condensation avoidance:

**L<sub>min</sub> = 210mm/8.3 inch:** „Steam manifold - Next steam manifold“ distance

**L<sub>4min</sub> = 120mm/4.7 inch:** „Lowest steam manifold - Duct bottom plane“ distance

**L<sub>5min</sub> = 120mm/4.7 inch:** „Highest steam manifold - Duct ceiling plane“ distance

Steam manifold arrangement for special air duct shapings

flat	steam manifold laterally staggered (with respect to air flow direction) in case of L <sub>min</sub> (s. above) not to be met																	
very flat	<p>by tilting the steam manifold 30 - 45° towards the air flow direction, the minimum upper clearance can be reduced to 70 mm/2.8 inch.</p> <table border="1" data-bbox="376 1429 906 1624"> <thead> <tr> <th>Min[mm/inch]</th> <th colspan="2">H1</th> <th>H2</th> </tr> <tr> <td></td> <th>30°</th> <th>45°</th> <td></td> </tr> </thead> <tbody> <tr> <td>DN25/1"</td> <td>182/7.2</td> <td>168/6.6</td> <td>225/8.6</td> </tr> <tr> <td>DN40/1 1/2"</td> <td>193/7.6</td> <td>179/7.2</td> <td>230/9.1</td> </tr> </tbody> </table>	Min[mm/inch]	H1		H2		30°	45°		DN25/1"	182/7.2	168/6.6	225/8.6	DN40/1 1/2"	193/7.6	179/7.2	230/9.1	<p>narrow channel</p>
Min[mm/inch]	H1		H2															
	30°	45°																
DN25/1"	182/7.2	168/6.6	225/8.6															
DN40/1 1/2"	193/7.6	179/7.2	230/9.1															
narrow, high	identical lengths one on top of the other, staggered laterally if possible																	
square	identical lengths, staggered vertically and laterally																	
low, very wide	facing each other																	

## Vertical steam manifold installation

### Steam manifold arrangement

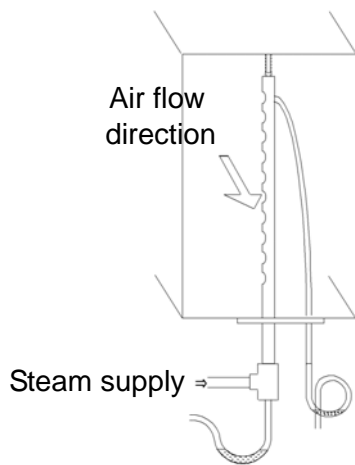

Horizontal installation of the steam manifolds is preferable. However, vertical installation into the air duct from below is also possible.

### **Standard manifold dimensions [mm]/ [inch]\*\*:**

I	220/ 8.7	400/ 15.7	600/ 23.6	900/ 35.4	1200 /47.2	1450 /57.1
DN25/1"	X	X	X	X	X	X
DN40/ 1 1/2"	X	X	X	X	X	X

\*\*\* Special lengths on demand.

**Number and size** of the steam manifolds available as well as the nominal diameter of the respective steam and condensate hoses may be taken from the tables shown in chapter „Technical Data“.

## 5.5 Steam line and condensate hose layout

### **Please note**

Because of the high requirements on hose material under the operating conditions given, it is recommended to use genuine Fisair hoses only.

### 5.5.1 Guide lines for steam line design

- Steam hose nominal diameter must not be smaller than the steam outlet of the Fisair steam humidifier (do not restrict the cross-section, otherwise back pressure will increase)
- Steam hoses must be laid without sags and kinks and with a continuous slope of 5-10% (otherwise sags may result).
- Steam hoses must be supported every 500 mm (20 inches) by clamp brackets
- Steam hoses should be kept as short as possible. Implement lengths beyond 5 m (16 ft.) as insulated fixed piping to keep energy loss and condensate generation to a minimum. Beyond 10 m (32 ft.) insulated installation is a must. Fixed piping is generally recommended for straight steam line segments
- When 2 steam manifolds are in use (other than with a standard implementation), place steam Y piece as close as possible to the steam manifolds. Such, for the main part of the piping just one steam hose is required and condensate loss is minimized
- Allow easy access to the steam pipe/ steam hose installation
- Pressure conditions within the duct are influenced by device steam output, steam line layout and the duct composition itself. In some rare situations it may become necessary to optimize steam line layout for achieving the results intended
- Respect minimum bending radii:

DN 25 Steam hose: Rmin = 200 mm/8"  
DN 40 Steam hose: Rmin = 400 mm/16"

### 5.5.2 Condensate hose layout

The condensate hose may be run from the steam manifold back to the steam cylinder, as depicted in the schematic drawing below with concern to installation type 1. Alternatively, the condensate hose may be fed directly in a wastewater pipe or a drain (s. installation type 2).

### **Please note**

Should condensate return into the steam cylinder be intended, the connection stub on the cylinder upper part must be drilled out first with a ANSI drill size „O“ drill. To do so, the steam cylinder must be removed from the housing (s. maintenance chapter, section „Steam cylinder removal and reinstallation“).

Drill out condensate hose connection stub with an 8 mm (ANSI drill size „O“) drill, if required

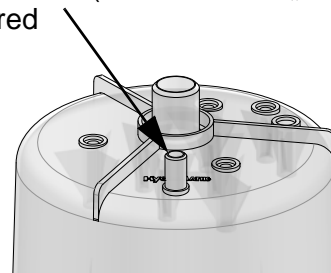

**Steam cylinder top view**

### 5.5.3 Steam line and condensate hose installation types

#### Installation type 1

Steam manifold is positioned more than 500 mm above device upper edge:

- » Run steam hose to a height of 400 mm/16 inch minimum above the steam humidifier and then to the steam manifold with a continuous incline of 5 to 10 %.
- » Feed condensate hose from steam manifold with a decline into waste-water pipe or drain.
- » As a steam barrier, lay out a 200 mm/8 inch min. loop (s. schematic representation below). Minimum distance from steam manifold to loop must be 500 mm/20 inch. Fill loop with water prior to steam humidifier commissioning.

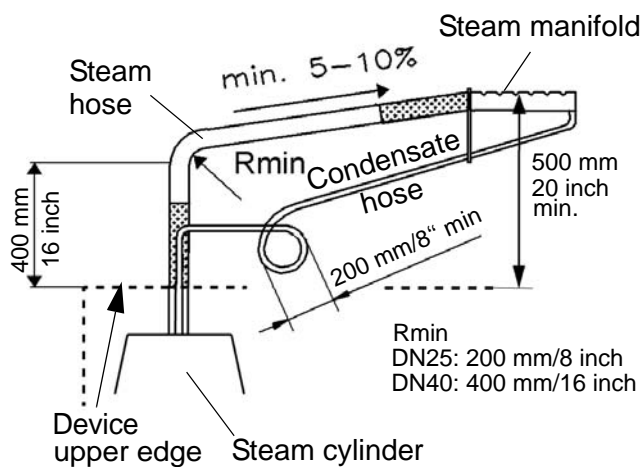

**Installation type 1,  
schematic representation**

#### Installation type 2

Steam manifold is positioned less than 500 mm above or below device upper edge:

**Please note**

In this arrangement the condensate hose cannot be fed back to the steam humidifier.

- » Run steam hose to a height of 400 mm/16 mm minimum above the steam humidifier and then to the steam manifold with a continuous decline of 5 to 10 %.
- » Feed condensate hose to a waste-water pipe/drain with a 200 mm/8 inch diameter loop as a steam barrier. Minimum distance from steam manifold to loop must be 500 mm/20 inch. Fill loop with water.

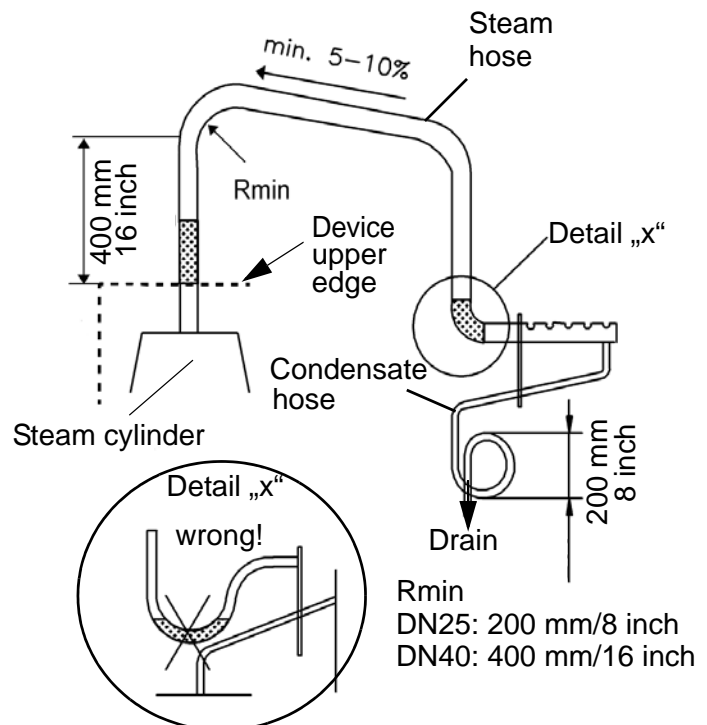

**Installation type 2,  
schematic representation**

## 6. Water connection

### **⚠ WARNING**

#### **Risk of scalding!**

Very hot water to be found in and around the steam humidifier during and after operation. Have all installation work done by expert staff in order to avoid scalding hazards due to improper water guidance.

### **⚠ WARNING**

#### **Risk of electrical shock!**

Hazardous electrical voltage!  
Before starting installation work ensure that the unit is not yet connected to the power supply.

### **General Rules**

- Obey local water utility regulations
- Verify that necessary safety measures have been taken – in compliance with either German Technical and Scientific Association for Gas and Water (DVGW) guidelines (DIN EN1717) or local regulations – that eliminate backflow of polluted water into drinking water treatment facilities. This may require the installation of a system separator of the CA type (minimum measure, allowable only when free discharge into the drainage system is given). Within the humidifier, a double check valve (58) is located in the water supply line. It prevents - in accordance with DIN EN 61770 - the backflow of water.
- Supply water must not exceed 40°C
- Allowable range of water pressure: 1 to 10 bar ( $100 \times 10^3$  to  $100 \times 10^4$  Pa)
- For connection to the water supply pipe, make use of a water hose
- Blow-down water must drain freely
- min. conductivity of feedwater:  $3 \mu\text{S/cm}$

## 6.1 Water supply

### **NOTICE**

**Foreign material in water supply pipe may cause premature wear of the solenoid valve.**

Flush the water supply pipe before making connection to the solenoid valve. This is of particular importance in case of a newly installed pipe.

- » Install a shut-off valve (SV) in the supply line.
- » Install a water filter (WF) if required due to bad water quality.

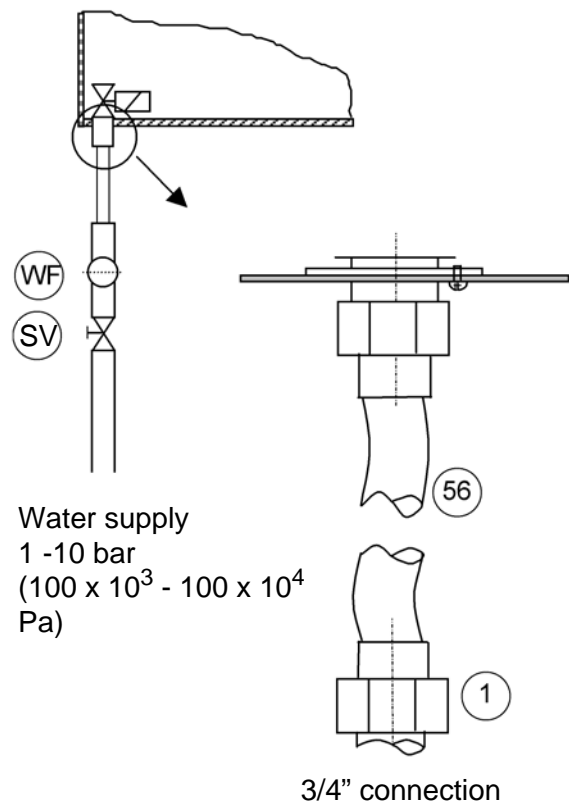

### **Please note**

Shut-off valve (SV) and water filter (WF) are not included in the delivery.

For connection to the water supply line, the water hose (56) with cap nuts (1) on both ends supplied with the unit may be used.

Make connection as follows:

- » Attach cap nut with inner seal ring to inlet screw joint on the humidifier housing and tighten.

**NOTICE**

**Do not overtighten the cap nut!**

Excessive tightening will destroy the fitting.

---

**Please note**

Strainer must be placed inside the solenoid valve.

---

- » Screw the other hose end cap nut with its inner seal on a customer-provided water tap (cap nut internal thread is  $\frac{3}{4}$ " ).

## 6.2 Water discharge

### **⚠ WARNING**

#### **Risk of scalding!**

During blow down, up to 0.3 l/sec are being drained with a temperature of about 95 °C. Ensure that the drain hose is reliably fastened and wastewater can drain freely and pressureless.

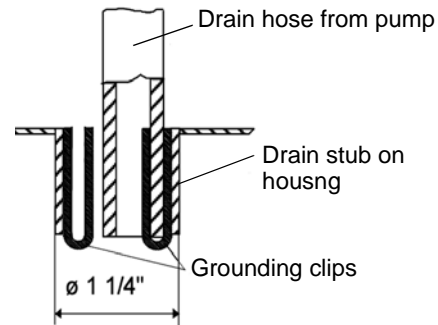

### **Please note**

Humidifier installation location and wastewater discharge must be on the same pressure level. In case of a drain connection on positive pressure, pls. consult your expert dealer.

### **Guidelines for water discharge composition**

- Use flexible water hose
- Do not buckle drain hose
- Discharge line and drain pipe material must be temperature resistant up to 95°C

### **How to proceed**

- » Run a 1 1/4 " drain hose of 250 to 1000 mm length into a pressure-free outlet according to DIN EN 1717. The hose must be guided sideways of the humidifier to prevent ascending vapor from condensating on the humidifier's housing.
- » Fit drain hose to connection stub on humidifier housing bottom side.
- » Slide pump drain hose onto one of the grounding clips (s. fig. below).
- » Slide overflow hose of the HyFlow system separator (if present) onto the other grounding clip.

### **Grounding clip functioning**

The two grounding clips attached to the inner surface of the housing drain stub are in direct contact with water and shunt potential residual electric currents away from the housing during blow-down and in case of a cylinder water overflow.

Between the pump drain hose jacket and the inner surface of the cabinet drain connection, a gap exists due to the diverging diameters. If water collects on the base plate, it will flow through this gap into the drain hose and then into the drainage system.

### **Please note**

With the optional wastewater cooling system **HyCool** (not available for FLP-XX-TPRO units), Fisair offers an option for limiting the steam humidifier wastewater temperature in order to protect thermosensitive wastewater pipe lines. By blending with tap water during blow-down, wastewater temperature is below 60 °C as long as inlet water temperature does not exceed 30 °C.

### **6.3 Water connections final check**

Go down the following water installation checklist:

- All screws and clamps properly tightened?
- Water supply line flushed before making connections?
- Water connection properly installed?
- Water discharge properly installed?
- Does blow-down water drain freely?
- Water supply line and water discharge leakage-free?

## 7. Electrical connection

### **⚠ WARNING**

#### **Risk of electrical shock!**

Hazardous electrical voltage.

All work related to electrical installation to be performed by expert staff (electricians or expert personnel with equivalent training) only.

### **Please note**

The customer is responsible for checking expert staff qualification.

Do not connect the steam humidifier to the live power supply before all installation work has been completed.

#### **General installation rules**

- All local rules concerning the implementation of electrical installations must be obeyed
- Electric connector cables to be laid professionally
- Install the electrical connections according to the wiring diagram
- With units of a nominal power output > 33 kW electrical connection to a permanent line is mandatory (according to VDE 0700 Part 98)

### **NOTICE**

#### **Possible electronical components destruction through electrostatical discharge!**

Prior to commencing electrical installation work, steps must be taken to guard the sensitive electronical components of the unit control against damage from electrostatical discharge.

## 7.1 Electrical installation approach

- » Provide fuses with a contact gap of at least 3mm per pole.
- » Install a separate main connection for each steam cylinder including main circuit breaker, main switch etc. .
- » Make main connection according to the table below.

#### **Main conection**

For the FlexLine steam humidifiers in the standard version, main connection is to be implemented as follows:

Model	Main connection
FLH03	220 - 240 VAC 1/N, 50 - 60 Hz
FLH06 FLH09 FLH15 FLH25 FLH30 FLH40 FLH50	380 - 415 VAC 3, 50 - 60 Hz

Other operating voltages on request.

#### **Fusing**

### **Please note**

Fisair recommends the use of slow blowing up to middle time-lag main fuses (applies only when the a.m. mains supply voltage is in use).

Steam humidifier installations should incorporate an individual residual current circuit breaker.

Maximum current draw of the FlexLine standard models and the required fusing resulting from that can be taken from the table below.

Model	Current draw [A]	Fusing [A]
FLH03	9,4 - 10,2	1 x 16
FLH06	10,7 - 11,7	3 x 16
FLH09	16,0 - 17,5	3 x 20
FLH15	15,6 - 17,1	3 x 20
FLH25	25,9 - 28,3	3 x 32 (35)
FLH30	31,2 - 34,1	3 x 35
FLH40	41,5 - 45,4	3 x 50
FLH50	51,8 - 56,6	3 x 63
FLH80	2 x (41,5 - 45,4)	6 x 50
FLH100	2 x (51,8-56,6)	6 x 63

### Characteristics of metric cable connections

Thread	Wrench size [mm]	Cable diameter supported [mm]
M25x1,5	30	9 - 17
M25x1.5 with MSI*)	30	6 (3 x)
M32x1,5	36	13 - 21
M40x1,5	46	16 - 28

\*) Multiple seal insert

## 7.2 Cable connections

The table below shows the number and dimensioning of the cable connections provided by the various FlexLine housing types.

Housing type	M25	M25 with MSI*)	M40	Ø 25 filler plug
FLH03 FL06/09	1	1		3
FLH15/25	1	1		3
FLH30/40 FLH50	0	1	1	3
FLH80/100	0	1	2	3

### 7.3 Safety interlock

#### **⚠ WARNING**

#### **Risk of electrical shock!**

Hazardous electrical voltage.

When standard wiring was made, terminal 1 shows 230 VAC after commissioning.

Across terminal 1 and 2 the so-called safety interlock is wired. This wiring allows for integration of safety devices. In case of an open safety interlock the steam humidifier does not operate.

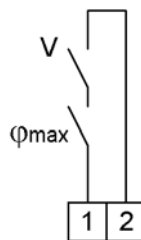

**Safety interlock terminals  
1/2 on main PCB**

#### **Please note**

Factory setting leaves the safety interlock open!

Install contact interlocks, e.g. a max. hygrosat, vane relays, pressure controllers, air interlock devices etc. in series across terminal 1 and 2.

#### **NOTICE**

**Contacts across terminals 1 and 2 must be potential free and properly rated!**

Rating must comply with the control voltage in use.

Best practice implies the integration of a max. hygrosat in the safety interlock wiring to protect against over-humidification due to a r.h. sensor malfunction.

### 7.4 Connection diagram

Pls. find the full wiring diagram in the „Flex-Line Control“ manual (section „Wiring Diagrams“).

### 7.5 Electrical installation check list

Check electrical installation with respect to customer-site requirements and local power supply regulations.

- Safety interlock properly wired across terminals 1 and 2?
- Supply voltage in accordance with name plate voltage rating?
- All electrical connections made according to the wiring diagram?
- Is the sensor (temperature sensor or r.h. sensor, depending on the application scenario) properly connected to the main p.c.b. ? (make sure that the input selected is adequate for the type of sensor installed with respect to the signal type and range specified).
- All screw terminal connections properly tightened?
- Have all electrical cable and plug connections been properly tightened?
- Proper unit grounding made?

## 8. Commissioning

### **▲WARNING**

#### **Risk of operating error!**

Start-up of the unit is restricted to expert staff only (electricians or expert personnel with equivalent training).

#### **Step 1: Check of mechanical integrity and wiring**

- » Open housing cover.
- » Check cylinder seating.
- » Check steam, condensate and drainhose clamps.
- » Check that all electrical wire connections (including steam cylinder wiring) are tight and secure.

#### **Step 2: Switching on the steam humidifier**

- » Switch on main breaker.
- » Open water supply stopcock (operating pressure should be 1bar min., 10bar max.).
- » Switch on unit by setting control switch to "I".

#### **Step 3: The unit performs a self-test and, then, commences normal operation**

- During self-test, the On/Off button icon  flashes for a couple of seconds
- On completion of the test, the software version is displayed for a short moment. Consequently, normal operation is commenced. However, steam is not produced without a demand pending

#### **Step 4: Trigger steam demand**

- » Set control for commissioning check for permanent steam demand and close safety interlock.

The water inlet solenoid valve opens and feeds water into the steam cylinder

#### **Step 5: Monitor unit function and check for leakage**

- » Let unit operate for 15 to 30 minutes.
- » If leaks appear, switch off the unit.

### **▲WARNING**

#### **Risk of electrical shock!**

Hazardous electrical voltage!

Follow safety instructions for work on live components.

#### **Step 6: Repair leaks**

- » Find leaks and eliminate.
- » Check again for leaks.
- » When everything is o.k., reattach housing cover.

## 9. Maintenance

### 9.1 General

For the achievement of a long unit life span, regular maintenance is a must. Maintenance works to be performed refer to unit assemblies that underlie either mechanical or electrical wear and tear, or may be impeded by residues in their proper functioning.

A steam humidifier's optimal performance and the maintenance intervals required primarily depend on the water quality encountered and the amount of steam produced. A particular water quality may shorten or lengthen maintenance intervals. The amount of residues found in the steam cylinder allows for a hint on future maintenance intervals.

Another scenario influencing the unrestricted unit availability is the main contactor lifetime in terms of a maximum number of switch cycles allowed, as indicated by its manufacturer. Unit control monitors the number of switch cycles and produces a service message when the max. number is reached.

#### 9.1.1 Service messages

In case of a service message produced, the Fisair logo in the main section of the touch display (for explanation s. „FlexLine controls“ manuals) is blanked. Instead, a frame is shown with the service icon  in it and a „Service message (xx)“ („xx“ indexes the message code). When the message frame is touched, the service message is displayed in clear language.

The service messages are listed in detail in the „FlexLine controls“ manuals. Following hereafter, pls. find 2 service messages denoted as examples:

- „*Steam\_amount\_counter*“ is output when the pre-set produced steam amount is reached. Maintenance of the device is necessary.
- „*Cycles\_main\_contactor x*“ is indicated when the number of cycles pre-set for main contactor „x“ (x = 1...5) is reached. The main contactor should then be replaced and the counter reset

(s. „Service“ submenu in the „FlexLine controls“ manuals).

After a „*Steam\_amount\_counter*“ message, maintenance work mainly encompasses checking and cleaning all of the unit parts including the steam cylinder inside, and a unit test run.

As part of the maintenance work, screw terminals and plug connections must be checked every time. If required, retightening the terminal screws is a must as well as ensuring tight fit of all of the plug connections.

Since steam and condensate hoses are subject to wear as well, hoses must also be checked regularly for tightness, flexibility and firm seating.

Seals are wear parts. As such, seal integrity checks and replacement is also a part of the regular maintenance work.

#### 9.1.2 Service messages for preventive maintenance

Fisair steam humidifiers continuously monitor the performance of the following functional areas:

- Blow-down operations
- Cylinder filling

When reaching pre-set trigger levels, unit control outputs preventive service messages that relate to the corresponding functional area.

The functional area addressed should then be checked at short term and maintained, if required (s. „FlexLine controls“ manuals, „Service messages and warnings“ chapter“).

### 9.1.3 Safety instructions for maintenance

#### **▲ WARNING**

##### **Risk of electrical shock!**

Hazardous electrical voltage. Unit must be switched off and protected against restart by expert staff (electricians or expert personnel with equivalent training) before any maintenance work is commenced.

---

#### **▲ WARNING**

##### **Risk of skin burning!**

Hot steam cylinder during operation and for some time afterwards.

Drain steam cylinder before any maintenance work is commenced. After that, wait approx. 10 mins before starting maintenance work.

Check steam cylinder temperature by cautious approximation with hand (do not touch!).

---

#### **▲ WARNING**

##### **Risk of scalding!**

Water pumped or drained from the steam cylinder may have a temperature of up to 95 °C.

Wear proper PPE (Personal Protection Equipment)!

---

#### **NOTICE**

##### **Take care of ESD protection!**

The electronic components of the humidifier control are very sensitive to electrostatic discharges. In order to protect these components during maintenance, steps must be taken to guard against damage from electrostatic discharge.

---

## 9.2 Maintenance frame work when unit is operated with fully demineralised water and condensate

Instructions on maintenance and cleaning intervals are entirely based on empirical data.

Cycle time	Maintenance work
<b>4 weeks after initial commissioning</b>	Visual inspection of electrical and mechanical connections. Visual inspection of level control. Visual inspection of the steam cylinder interior.
<b>anually</b>	Visual inspection of electrical and mechanical connections. Visual inspection of level control. Visual inspection of heater element and thermo switch Visual inspection of steam cylinder interior.  If required, cleaning of steam cylinder, heater element, thermo switch and level control followed by the replacement of all sealing.

## 9.3 Maintenance when unit is operated with tap water or partially softened water

No precise maintenance intervals can be specified because these always depend on water quality and the amount of steam generated. It is advisable to adjust the frequency of maintenance to the specific operational experience. Fisair recommends to check the opened steam cylinder 1 or 2 weeks after initial commissioning in order to quantify the amount of residue produced so far, allowing for determining future maintenance intervals and/or the adjustment of blow-down cycles possibly required.

### Blow-down cycles

The vaporisation process causes hardness builders (calcium) in form of solids of various compositions to fall out within the steam cylinder. Cyclic blow-down by means of a powerful blow-down pump followed by fresh water refills remove parts of this solid built-up.

### Water quality

When tap water is used, it must be taken into account that cleaning intervals shorten as the carbonate hardness level increases. As a general rule, it is preferable to operate the unit with fully demineralized water since operation will not be affected by mineral deposits and flushing loss will be minimized.

#### **Please note**

Possibly, maintenance intervals may be extended by moderately increasing the blow-down cycle rate. Please consult your expert dealer.

## 9.4 Removing and cleaning the steam cylinder

### **CAUTION**

#### **Risk of eye injuries!**

The clips that fix the steam cylinder halves have sharp edges and can jump off during dismantling.

Eye injuries possible.

Wear proper PPE (Personal Protection Equipment)!

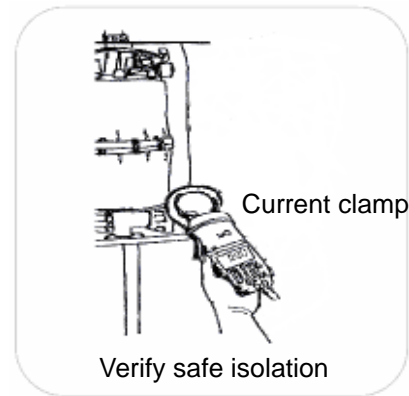

### Steam cylinder removal

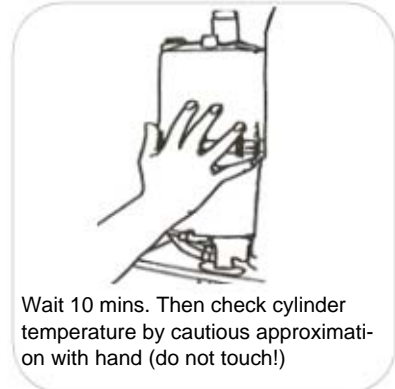
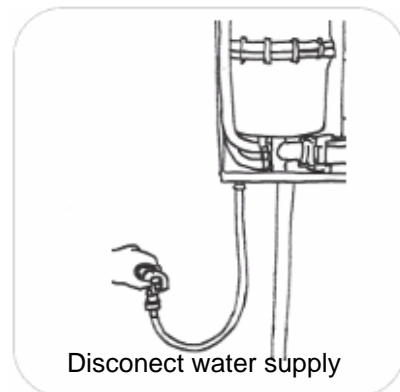
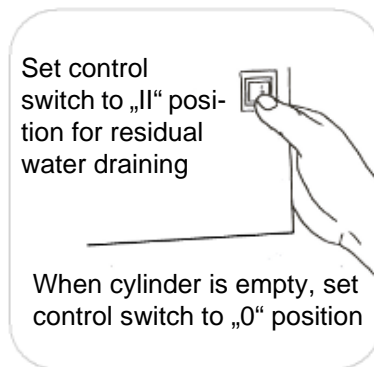

- » Remove unit housing cover

- » Remove water sensor hose from cylinder top.
- » Remove SuperFlush solenoid hose from cylinder bottom (if applicable).
- » Remove steam hose from steam hose adapter.

If the steam hose is not to be disconnected, the steam hose adapter with the steam hose still attached may be detached from the steamcylinder as shown in the next figure.

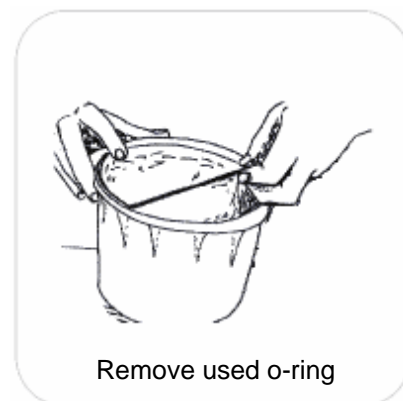
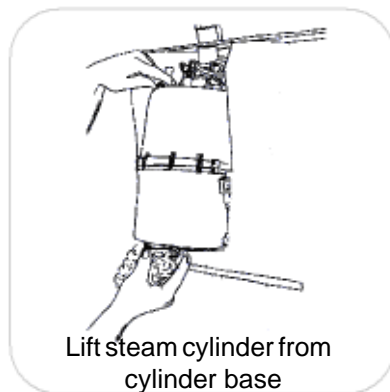
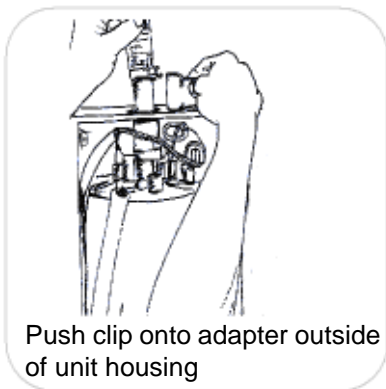
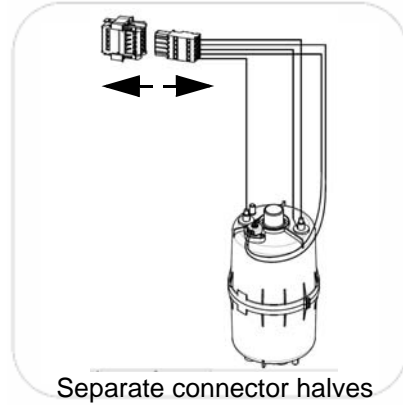
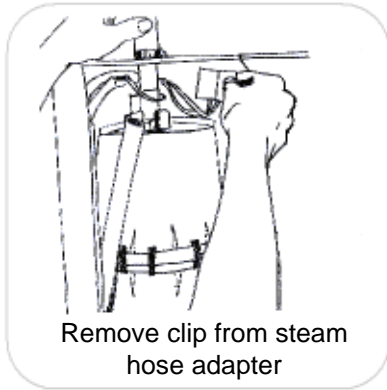

## Reinstallation

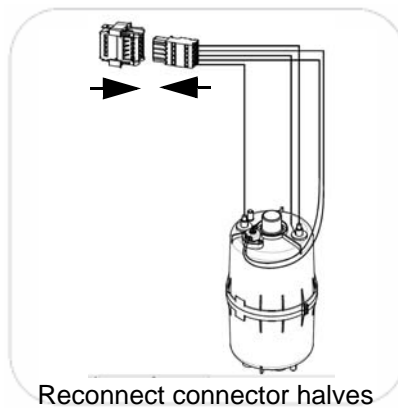
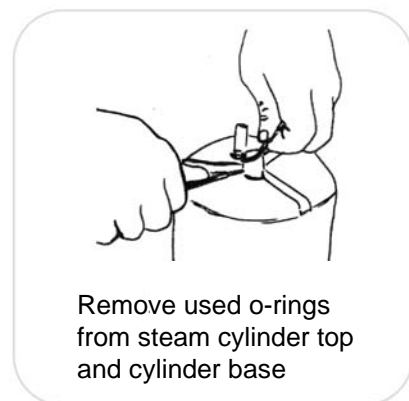
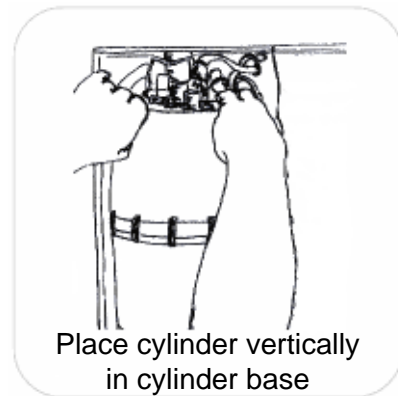

- » Reattach level control hose to cylinder cover.
- » Reattach SuperFlush solenoid hose to steam cylinder bottom stub.
- »

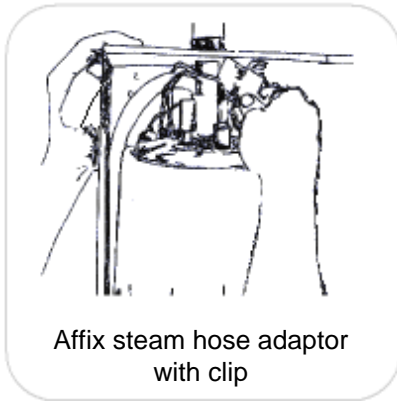
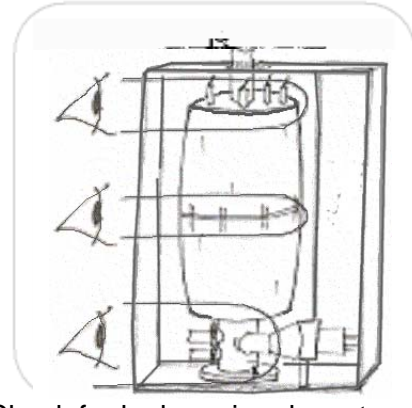

» Reattach unit housing cover

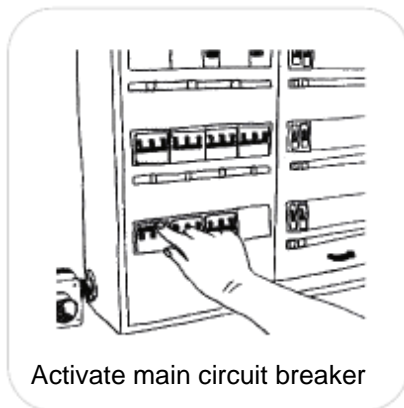
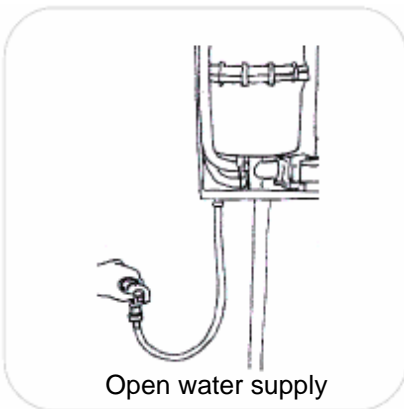

## 9.5 Steam cylinder and cylinder base cleaning

Removal of the steam cylinder is described in the „Removal and reinstallation of the steam cylinder“ section.

### **NOTICE**

#### **Risk of material damage!**

Excessive force when cleaning the cylinder or the heater element(s) may harm these device parts.

### **NOTICE**

#### **Risk of functional disruption!**

Use descaler or cleaning detergents only for cylinder and heater element cleaning. Do not introduce in cylinder base or apply to hoses!

Prior to restarting the unit, make sure that the device assemblies in question are thoroughly flushed or rinsed.

- » Remove all deposits. Small amounts of scale deposits on the heater element(s), however, are harmless.

### Steam cylinder cleaning

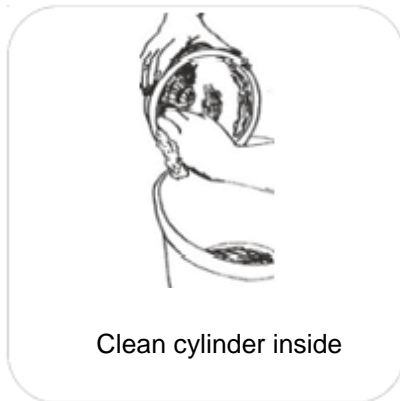

### Cylinder base cleaning

Just as the cylinder, the cylinder base and its connection joints must be checked for deposits and cleaned, if required.

## 9.6 Level control device cleaning

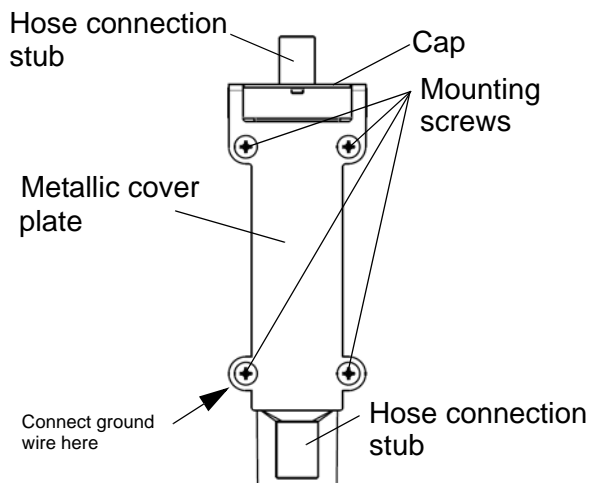

**Water sensor**

The level control device is accessible only after removal of the steam cylinder.

- » Disconnect hoses from level control device connection stubs on upper and lower side
- » Remove the 4 screws securing the metallic cover plate of the level control device and the device as such against the unit rear wall. Memorize ground wire attachment position (under lower left hand side screw).
- » Unclip level control device enclosure cap with a flick of the thumb and remove.
- » Take out o-ring and dispose of.
- » Make visual inspection of level control device enclosure interior and clean, if required. Scratch out any deposits, if present.
- » Inspect both level control connection hoses and clean, if required.
- » Insert new o-ring.
- » Re-attach enclosure cap.
- » Align metallic plate with level control device enclosure mounting holes and insert screws in upper left and lower right position. Reintroduce level control device into humidifier housing and loosely affix to unit rear wall with the 2 screws.

- » Insert the 2 screws remaining into the open level control device enclosure mounting holes while positioning the ground wire connection eyelet under the lower left screw.
- » Handtighten all of the screws.

### **Please note**

A functional check of the level control device may only be accomplished while the device is installed into the unit!

## 9.7 Heater element replacement

### Removal

- » Remove and open steam cylinder as described in the „Removing and cleaning the steam cylinder“ section.
- » Separate thermo switch capillary tube from heater element(s) by detaching the retainer clips.
- » Remove wiring of the heater element(s) in question from connector terminals (mark positions for reclamping).
- » Unscrew heater element fixing nut(s) from cylinder cover.
- » Remove adjusting washer and grounding lug/lock washer (if present) and pull heater element/s downward out of steam cylinder cover.
- » Clean the sealing surface on the underside of the cover around the area where the new heater element will be installed.

### Reinstallation

- » Install replacement heater element(s) (with new sealing) while considering the correct sequence of all of the mounting parts. Ensure proper grounding and tighten nut(s).
- » Insert heater element wires into the terminals of the wiring connector following the markings made when disassembling. Polarity is not an issue.
- » Refit thermo switch capillary tube to heater element(s) using retainer clips.
- » Reassemble steam cylinder and reinstall in humidifier housing as described in the „Removing and cleaning the steam cylinder“ section.

## 9.8 Thermo switch replacement (for heater elements)

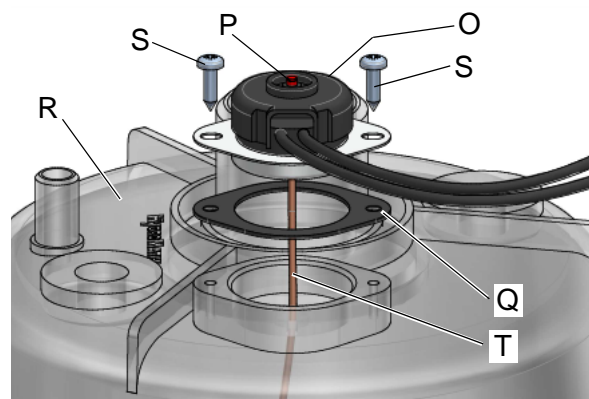

- O: Thermo switch
- P: Thermo sensor release button
- Q: Seal
- R: Steam cylinder
- S: Screw
- T: Capillary tube

### Removal

- » Remove and open the steam cylinder as described above in “Removing and cleaning the steam cylinder” section.
- » Remove wiring of the thermo switch from connector terminals (mark positions for reclamping).
- » Detach capillary tube (T) retainer clips from heater element(s).
- » Separate capillary tube from heater element(s) (4).
- » Unscrew the two screws holding thermo switch (S) in place.
- » Pull out thermo switch (O) upwards off steam cylinder cover (R).

### **NOTICE**

#### **Risk of material damage!**

Do not buckle the thermo switch capillary tube!

## Reinstallation

- » Install replacement thermo switch with a new sealing.
- » Properly connect the capillary tube to the heater element. In case of humidifiers with several heating elements, the capillary tube is attached to three heating elements.
- » Insert thermo switch wires into the terminals of the wiring connector following the markings made when disassembling.
- » Reassemble steam cylinder and reinstall in humidifier housing as described in the „Removing and cleaning the steam cylinder“ section.

## 9.9 Releasing a thermo switch that has triggered

To protect the steam humidifier against thermal overload, the unit is equipped with one or two thermo switches, depending on the unit capacity. Mounting positions for the thermo switches are on the cylinder cover. One of the thermo switches (or „the“ one, in case of only one thermo switch present) features a capillary tube for thermal coupling to the heater element. Additionally, the solid state relay is protected with a bi-metal switch attached to the heat sink to prevent damages caused by inadequate ventilation through e.g. covered vents.

From an electrical point of view, all of the thermo switches are connected in series. In case of one of the thermo switches triggering due to a temperature too high, the main contactor K1 drops, while the electronic control enters fault state „120“, i. e. „Thermoswitch“.

In case of one of the thermo switches triggering repeatedly, the reason for this must be identified prior to further unit usage.

## Thermo switch(es) on steam cylinder cover.

After the unit has cooled down, the thermo switch that has triggered may be identified by passage measurement, as long as it is a thermo switch on a steam cylinder. Unblocking the thermo switch is accomplished as follows:

Slightly push down the red button (s. above section) protruding a few millimeters from its holder. This will make the button return to its original position and unblock the mechanism.

Relasing a thermo switch does not erase the fault message in the control fault memory.

## Thermo switch on solid state relay

The thermo switch attached to the solid state relay is a bi-metal switch without an unblocking feature. Instead, after cool-down, the switch will be unblocked automatically. Restarting the steam humidifier is only possible after cool-down.

## 9.10 Inspection of wiring connections and heater element wiring

### **NOTICE**

#### **Risk of functional disruption!**

#### **Risk of material damage!**

Loose cable connections may result in increased transition resistance and contact area overheating.

- » Check all cabling terminals and plugs for tight seating. Plugs must sit on their respective contacts as far as they will go.
- » Check heater element wiring for damaged insulation

## 9.11 Removal and reinstallation of the solenoid valve including fine filter cleaning

### Removal

- » Shut off water supply and disconnect tap water hose cap screw connection.
- » Remove connecting hose (20) from solenoid valve.
- » Detach electrical cable connector from solenoid valve (25).
- » Unscrew solenoid valve mounting screws.
- » Remove solenoid valve from housing bore.

### Fine filter cleaning

- » Remove fine filter from solenoid valve tap water connection side and clean under running water.

### Reinstallation

- » Reinsert fine filter into solenoid valve.
- » Reinsert solenoid valve with seal in unit housing bore.
- » Bolt-down solenoid valve.
- » Reestablish tap water connection.
- » Reconnect electrical cable to solenoid valve.
- » Reattach connecting hose (20) to solenoid valve using clamp.
- » Turn on water tap.
- » Switch on unit and check for leakages after 15 to 30 mins of operation.

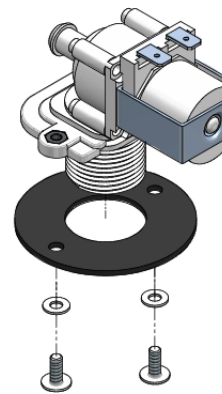

**Solenoid valve**

### **⚠ WARNING**

#### **Risk of electrical shock!**

Hazardous electrical voltage!

Follow safety instructions for work on live components.

Leakages may invoke leak currents.

- » In case of leakage turn off power supply and secure against being switched on again.
- » Find leakage and eliminate.
- » Check again.

## 9.12 Cleaning of blow-down pump

### Removal and cleaning

- » Remove steam cylinder as described in „Removal and reinstallation of steam cylinder“ section.
- » Detach adapter (30) from pump (32).
- » Detach electrical cable from pump.
- » Unscrew mounting screws from housing bottom plate (safe vibration buffer, bolts and washers for reinstallation) and pull pump out of cylinder base (37).
- » Open pump bayonet lock.
- » Remove residues from pump and drain hoses (replace O-ring if required).

### Reinstallation

- » Moisten O-ring (33) and insert into cylinder base (37) horizontal stub.
- » Push pump back into cylinder base and bolt to bottom plate incorporating the vibration buffer and washers saved during removal.
- » Moisten O-ring (31) and insert into adapter.
- » Slide adapter (30) onto pump stub.
- » Refit electrical cable to pump connector (no polarisation).
- » Let unit run for 15 to 30 mins, then check for leakages.

- » in case of leakage turn off power supply and secure against being switched on again.
- » Find leakage and eliminate.
- » Check again.

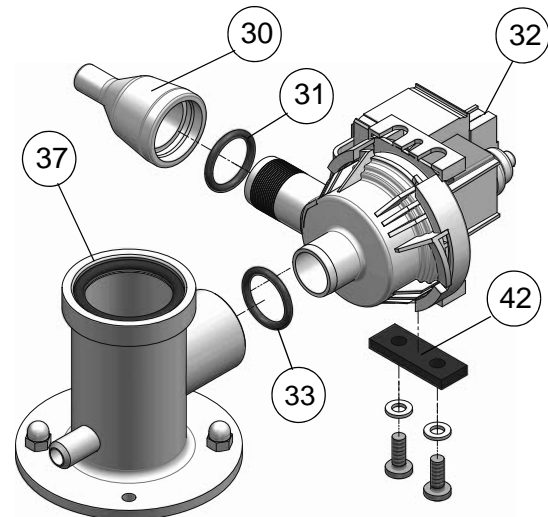

**Blow-down pump**

### **⚠ WARNING**

#### **Risk of electrical shock!**

Hazardous electrical voltage!  
Follow safety instructions for work on live components.  
Leakages may invoke leak currents.

## 9.13 Inspection of hoses

Since steam and condensate hoses are prone to wear as well, those hoses should undergo regular checks as well.

## 9.14 Functional check

- » Run the system with maximum output for a couple of minutes
- » Check all safety devices.
- » Check hose connections and seals for leakage.

## **9.15 Completion of maintenance**

After completion of the extensive maintenance work the service interval is reset by using the parameter "Reset\_cyl. 1" or "Reset\_cyl. 2" (only for double cylinder units). In doing so the steam counter contains again the preset value after which next maintenance is required (see operating instructions FlexLine Controls ", submenu "Service").

## 10. Dismantling

Once the steam humidifier will no longer be used, dismantle (demolish or scrap) it by following the installation procedures in reverse order.

### **▲ WARNING**

**Warning:** Dismantling of the unit may only be performed by qualified personnel. Electrical dismantling may only be performed by trained electricians.

---

### **Please note**

Obey the safety guidelines in section “Safety Instructions,” especially the guidelines for disposal.

---

## 11. Declaration of Conformity



### EU Konformitätserklärung EU Declaration of Conformity

**Hersteller / Manufacturer:** HygroMatik GmbH

**Anschrift / Address:** Lise-Meitner-Straße 3, D-24558 Henstedt-Ulzburg, Germany

**Produktbezeichnung:  
/ Product description** **FlexLine Heizkörper (FLH):**  
FLH03\*, FLH06\*, FLH09\*, FLH15\*, FLH25\*, FLH40\*, FLH50\*  
FLH80\*, FLH100\*  
\*( sowie Ausführungen , -T, oder -TSPA)

**Die bezeichneten Produkte stimmen in der von uns in Verkehr gebrachten Ausführung mit den Vorschriften folgender Europäischer Richtlinien überein:**

*The products described above in the form as delivered are in conformity with the provisions of the following European Directives:*

- |                   |   |
|-------------------|---|
| <b>2014/30/EU</b> | Richtlinie des Rates zur Angleichung der Rechtsvorschriften der Mitgliedstaaten über die elektromagnetische Verträglichkeit.<br><i>Council Directive on the approximation of the laws of the Member States relating to electromagnetic compatibility.</i>   |
| <b>2014/35/EU</b> | Richtlinie des Rates zur Angleichung der Rechtsvorschriften der Mitgliedstaaten betreffend elektrische Betriebsmittel zur Verwendung innerhalb bestimmter Spannungsgrenzen.<br><i>Council Directive on the approximation of the laws of the Member States related to electrical equipment designed for use within certain voltage limits.</i> |

Die Konformität mit den Richtlinien wird nachgewiesen durch die Einhaltung folgender Normen:  
*Conformity to the Directives is assured through the application of the following standards:*

<b>Referenznummer:</b>	<b>Ausgabedatum:</b>	<b>Referenznummer:</b>	<b>Ausgabedatum:</b>
<i>Reference Number:</i>	<i>Edition:</i>	<i>Reference Number:</i>	<i>Edition:</i>
DIN EN 61000-6-2	2006-03	DIN EN 60335-1	2012-10
DIN EN 61000-6-3	2011-09	DIN EN 60335-1 Ber.1	2014-04
DIN EN 62233	2008-11	DIN EN 60335-2-98	2009-04
DIN EN 62233 Ber.1	2009-04		

Das Produkt entspricht den Anforderungen des deutschen Produktsicherheitsgesetzes ProdSG hinsichtlich der Gewährleistung von Sicherheit und Gesundheit. Produktänderungen nach Auslieferung können zum Verlust der Konformität führen.

*The requirements of the German Product Safety Law ProdSG regarding the ensurance of safety and health are met. Product modifications after delivery may result in a loss of conformity.*

Henstedt-Ulzburg, den / the 29.09.2017

HygroMatik GmbH

Dirc Menssing  
Geschäftsführer / General Manager

i.V. Frank Michaelsen  
Leitung Technik / Head of Engineering

Diese Erklärung bescheinigt die Übereinstimmung mit den genannten Richtlinien, ist jedoch keine Zusicherung von Eigenschaften. Die Sicherheitshinweise der mitgelieferten Produktdokumentation sind zu beachten.  
*This declaration certifies the conformity to the specified directives but contains no assurance of properties. The safety documentation accompanying the product shall be considered in detail.*

## 12. Spare Parts

*	FLH03	FLH06	FLH09	FLH15	FLH25	FLH30	FLH40	FLH50	FLH80	FLH100	Article No.	Description
<b>Steam generation 220-240V</b>												
16	1										SP-03-01020	Steam cylinder FLH03 CY08 220-240V, incl. O-ringset
16		1									SP-03-01050	Steam cylinder FLH06 CY08 220-240V, incl. O-ringset
16				1							SP-04-01020	Steam cylinder FLH15 CY17 220-240V, incl. O-ringset
16							1				SP-06-01080	Steam cylinder FLH30 CY45 220-240V, incl. O-ringset
4	1										SP-03-01100	Heating element CY08 3kg 220-240V, incl. gaskets
4		1									SP-03-01101	Heating element CY08 6kg 220-240V, incl. gaskets
4				3			6				SP-07-01100	Heating element CY17/45 6kg 220-240V, incl. gasket
<b>Steam generation 380-415V</b>												
16		1									SP-03-01051	Steam cylinder FLH06 CY08 380-415V, incl. O-ringset
16			1								SP-03-01080	Steam cylinder FLH09 CY08 380-415V, incl. O-ringset
16				1							SP-04-01021	Steam cylinder FLH15 CY17 380-415V, incl. O-ringset
16					1						SP-04-01050	Steam cylinder FLH25 CY17 380-415V, incl. O-ringset
16							1				SP-06-01081	Steam cylinder FLH30 CY17 380-415V, incl. O-ringset
16								1	2		SP-06-01021	Steam cylinder FLH40/80 CY45 380-415V, incl. O-ringset
16								1		2	SP-06-01050	Steam cylinder FLH50/100 CY45 380-415V, incl. O-ringset
4		1									SP-03-01102	Heating element CY08 6kg 380-415V, incl. gaskets
4			1								SP-03-01105	Heating element CY08 9kg 380-415V, incl. gaskets
4				3			6	3		6	SP-07-01101	Heating element CY17/45 5kg 380-415V, incl. gasket
4					3		3	6	6	12	SP-07-01104	Heating element CY17/45 8,4kg 380-415V, incl. gasket
<b>Steam generation 440-480V</b>												
16		1									SP-03-01052	Steam cylinder FLH06 CY08 440-480V, incl. O-ringset
16			1								SP-03-01081	Steam cylinder FLH09 CY08 440-480V, incl. O-ringset
16				1							SP-04-01022	Steam cylinder FLH15 CY17 440-480V, incl. O-ringset
16					1						SP-04-01051	Steam cylinder FLH25 CY17 440-480V, incl. O-ringset
16							1				SP-06-01082	Steam cylinder FLH30 CY17 440-480V, incl. O-ringset
16								1	2		SP-06-01022	Steam cylinder FLH40/80 CY45 440-480V, incl. O-ringset
16								1		2	SP-06-01051	Steam cylinder FLH50/100 CY45 440-480V, incl. O-ringset
4		1									SP-03-01103	Heating element CY08 6kg 440-480V, incl. gaskets
4			1								SP-03-01107	Heating element CY08 9kg 440-480V, incl. gaskets
4				3			6	3		6	SP-07-01102	Heating element CY17/45 5kg 440-480V, incl. gasket
4					3		3	6	6	12	SP-07-01105	Heating element CY17/45 8,4kg 440-480V, incl. gasket
<b>Steam generation 600-690V</b>												
16		1									SP-03-01053	Steam cylinder FLH06 CY08 600-690V, incl. O-ringset
16			1								SP-03-01082	Steam cylinder FLH09 CY08 600-690V, incl. O-ringset
16				1							SP-04-01023	Steam cylinder FLH15 CY17 600-690V, incl. O-ringset
16					1						SP-04-01052	Steam cylinder FLH25 CY17 600-690V, incl. O-ringset
16							1				SP-06-01083	Steam cylinder FLH30 CY17 600-690V, incl. O-ringset
16								1	2		SP-06-01023	Steam cylinder FLH40/80 CY45 600-690V, incl. O-ringset
16								1		2	SP-06-01052	Steam cylinder FLH50/100 CY45 600-690V, incl. O-ringset
4		1									SP-03-01104	Heating element CY08 6kg 600-690V, incl. gaskets
4			1								SP-03-01107	Heating element CY08 9kg 600-690V, incl. gaskets
4				3			6	3		6	SP-07-01103	Heating element CY17/45 5kg 600-690V, incl. gasket
4					3		3	6	6	12	SP-07-01106	Heating element CY17/45 8,4kg 600-690V, incl. gasket
<b>Steam generation general</b>												
	1	1	1								AC-03-01000	O-ringset (Pos. 3, 7, 17, 31, 33, 34, 35)
				1	1						AC-04-01000	O-ringset (Pos. 3, 7, 17, 31, 33, 34, 35)
						1	1	1	2	2	AC-06-01000	O-ringset (Pos. 3, 7, 17, 31, 33, 34, 35)
5	1	1	1	1	1	2	2	2	4	4	B-2205031	Thermal circuit breaker steam cylinder incl. incl. gasket, clips
27	1	1	1	1	1						CN-07-01010	Water level sensor complete with cable, short
27						1	1	1	2	2	CN-07-01012	Water level sensor complete with cable, long
1	1	1	1								E-2209018	Adapter for Steam hose for cylinder CY08 DN40-25
1				1	1	2	2	2	4	4	E-2209008	Adapter for Steam hose for cylinder CY17/45 DN40-40
2	1	1	1	1	1	2	2	2	4	4	E-2209002	Clip for adapter
<b>Water feed</b>												
25	1	1	1								WF-03-00012	Solenoid valve FLH03-09 220-240V 0,2 - 10bar with mounting set
25				1	1						WF-04-00012	Solenoid valve FLH15-25 220-240V 0,2 - 10bar with mounting set
						1	1	1	2	2	WF-06-00012	Solenoid valve FLH40-50 220-240V 0,2 - 10bar with mounting set
	1	1	1								WF-03-01001	Water feed hose system (Pos: 21, 22, 23, 24)
				1	1						WF-04-01001	Water feed hose system (Pos: 21, 22, 23, 24)
						1	1	1	2	2	WF-06-01001	Water feed hose system (Pos: 21, 22, 23, 24)
56	1	1	1	1	1	1	1	1	2	2	B-2304031	Water inlet hose connection, 0,6m 3/4"
<b>Water drain</b>												
	1	1	1								B-2425005	Pump-drain-hose-system incl. o-ring (Pos. 6, 14, 15, 30, 31)
				1	1	1	1	1	2	2	B-2425009	Pump-drain-hose-system incl. o-ring (Pos. 6, 14, 15, 30, 31)
	1	1	1	1	1	1	1	1	2	2	B-2404027	Drain pump without mounting set Pos: (Pos. 31, 32, 33)
42	1	1	1	1	1	1	1	1	2	2	B-2424014	Mounting set for drain pump

*	FLH03	FLH06	FLH09	FLH15	FLH25	FLH30	FLH40	FLH50	FLH80	FLH100	Article No.	Description
<b>Electrics</b>												
<b>Main contactor 380-415V</b>												
	1	1	1								E-2507040	Main contactor 20A, K1.1 - FLH03-09
				1	1						E-2507060	Main contactor 35A, K1.1 - FLH15-25
						1					E-2510020	Main contactor 35A, K1.1 - FLH30
						1					E-2507040	Main contactor 20A, K1.2 - FLH30
							1		2		E-2507070	Main contactor 50A K1.1 - FLH40/80
							1		3		E-2510020	Main contactor 35A K1.2 - FLH40/80
								1		2	E-2507080	Main contactor 65A, K1.1 - FLH50/100
								1		3	E-2510020	Main contactor 35A K1.2 - FLH50/100
1	1	1									CN-03-01000	Solid state relay for FLH03-09 incl. heatsink & temp. limiter
				1	1	1	1	1			CN-07-01000	Solid state relay for FLH15-50 incl. heatsink & temp. limiter
									1	1	B-2602009	Solid state relay for FLH80-100 incl. heatsink & temp. limiter
1	1	1									WR-03-01010	Connector e-compartment - water compartment, plug + socket
				1	1	2	2	2	4	4	WR-07-01010	Connector e-compartment - water compartment, plug + socket
1	1	1	1	1	1	1	1	1	1	1	CN-07-00020	Mainboard incl. Plug, fuse 2.5A
1	1	1	1	1	1	1	1	1	1	1	CN-07-00025	Mainboard incl. Plug, fuse 0.5A
									1	1	CN-07-00030	Extension board double cylinder FlexLine
1	1	1	1	1	1	1	1	1	1	1	CN-07-00021	Touch Display FlexLine
1	1	1	1	1	1	1	1	1	1	1	E-2502412	Control switch, double pole, middle position = "0"
<b>Accessories</b>												
70											E-2604012	Steam hose DN25, per m
70											E-2604013	Steam hose DN40, per m
57											E-2420423	Drain hose 1 1/4", per m
											E-2604002	Condensate hose DN12, per m
											E-2404004	Steam hose clamp DN25
											E-2604016	Steam hose clamp DN40
											E-2404010	Clamp for drain hose 1 1/4"
											E-8501064	Condensate hose clamp
											E-2604042	Connectors for steam distribution T-piece DN25, stainless steel
											E-2604023	Connectors for steam distribution T-piece DN40, stainless steel
											E-2604021	Connectors for condensate T-piece DN12

If you order any spare parts, please specify type and serial number of the unit.  
 \* see Exploded View

For ordering spare parts, a template can be found on the [www.fisair.com](http://www.fisair.com) website under the „Contact“ tab. Your spare parts order may as well be directed per e-mail to the Fisair main office using the address [info@fisair.com](mailto:info@fisair.com).

Please make sure to specify your unit model and serial number.

## 13. Technical specifications

### FLH Steam Humidifier Climate

Technical specifications FlexLine Heater						
Unit type	FLH06	FLH09	FLH15	FLH25	FLH30	FLH40
Steam output [kg/h]	5,5-6,5	8,2-9,8	13,7-16,4	22,7-27,1	27,4-32,7	36,5-43,5
Electrical connection <sup>(1)</sup>	380-415V /3Ph /50-60Hz					
Rated power [kW]	4,1-4,9	6,2-7,3	10,3-12,3	17,1-20,3	20,6-24,5	27,3-32,6
Nominal current [A]	10,7-11,7	16-17,5	15,6-17,1	25,9-28,3	31,2-34,1	41,5-45,4
Fuse [A]	3 x 16	3 x 20		3 x 32	3 x 35	3 x 50
Number of steam cylinder	1					
Control	FlexLine mainboard with capacitive 3.5" touch colour display					
Separate control voltage <sup>(4)</sup>	220-240V /N /2,5A					
Steam hose connection [mm]	1 x 25			1 x 40	1 x 40 <sup>(5)</sup>	2 x 40
Empty weight [kg]	19		25		36	37
Max. filling capacity [l]	5		14		36	
Operation weight [kg]	24		40		72	74
Width <sup>(6)</sup> [mm]	540				640	
Height <sup>(6)</sup> [mm]	535		695		785	
Depth <sup>(6)</sup> [mm]	320				420	
Water connection	fully demineralized water / cleaned condensate / partially softened tap water of varying qualities 1 to 10bar, 1 to 10 bar, for 3/4" external thread					
Drain water connection	Connection Ø 1 1/4"					

Technical specifications FlexLine Heater			
Unit type	FLH50	FLH80	FLH100
Steam output [kg/h]	45,5-54,3	73,0-87,0	91,0-108,5
Electrical connection <sup>(1)</sup>	380-415V /3Ph /50-60Hz		
Rated power [kW]	34,1-40,7	2 x 27,3-32,6	2 x 34,1-40,7
Nominal current [A]	51,8-56,6	2 x 41,5-45,4	2 x 51,8-56,6
Fuse [A]	3 x 63	2 x 3 x 50	2 x 3 x 63
Number of steam cylinder	1	2	
Control	FlexLine mainboard with capacitive 3.5" touch colour display		
Separate control voltage <sup>(4)</sup>	220-240V /N /2,5A		
Steam hose connection [mm]	2 x 40	4 x 40	
Empty weight [kg]	37	75	80
Max. filling capacity [l]	36	71	
Operation weight [kg]	74	147	152
Width <sup>(6)</sup> [mm]	640	1170	
Height <sup>(6)</sup> [mm]	785		
Depth <sup>(6)</sup> [mm]	420		
Water connection	fully demineralized water / cleaned condensate / partially softened tap water of varying qualities 1 to 10bar, 1 to 10 bar, for 3/4" external thread		
Drain water connection	Connection Ø 1 1/4"	2x Connection Ø 1 1/4"	

<sup>(1)</sup> Other voltages upon request.

<sup>(4)</sup> Internal control voltage upon request.

<sup>(5)</sup> Incl. Y-piece DN40.

<sup>(6)</sup> Outer dimensions of width and depth. Height incl. drain connection.



## 14. Exploded view

The figure following shows the FLH model composition. The number of cylinders and heater elements vary with respect to the complete FLH series.

The index numbers in the figure correspond to the spare parts list.

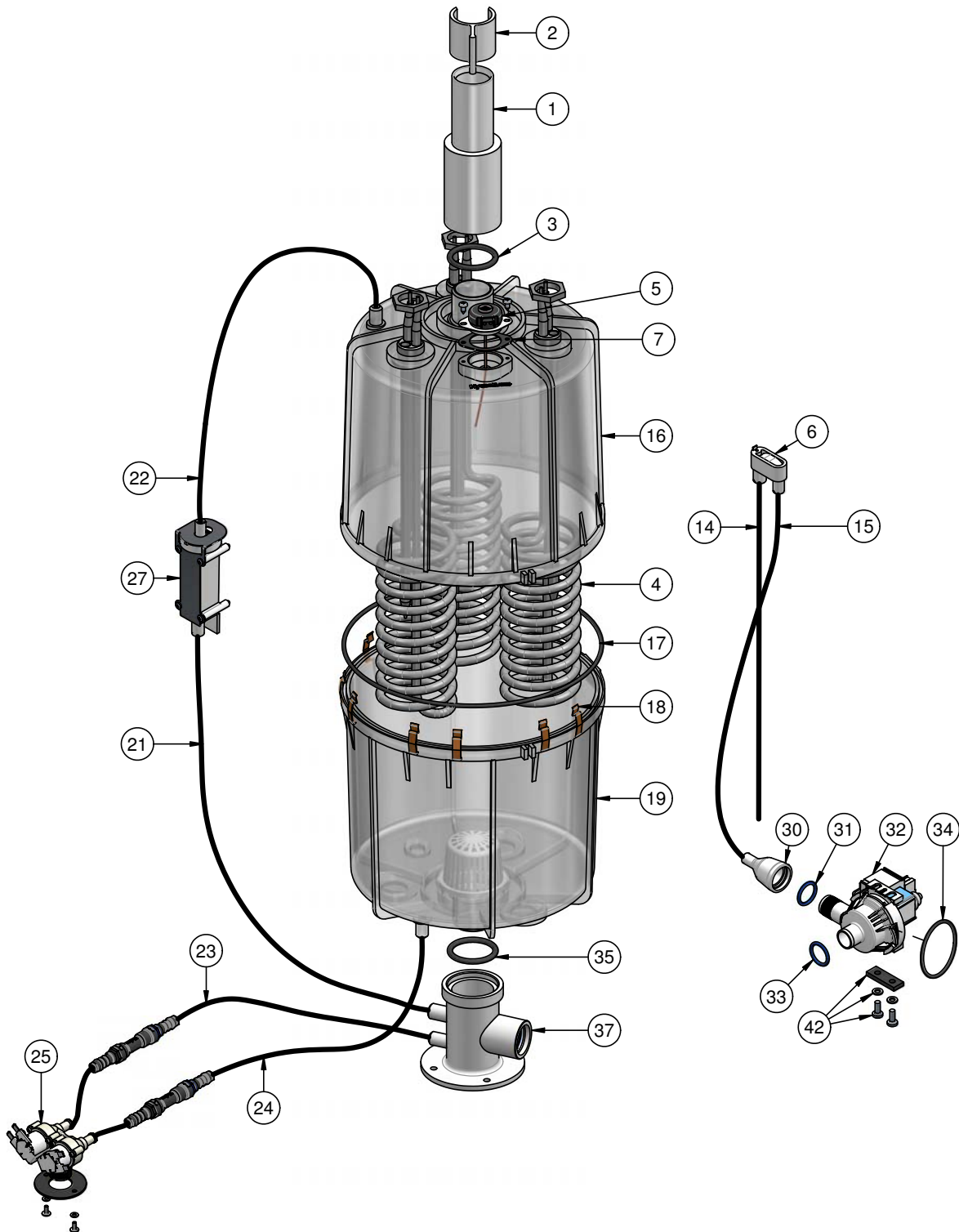

## 15. View of housing





**fisair**  
air humidity control 